



| APPLICABLE STANDARD | | | | | |
|---|--|--------------------------|---|-----------------------------|---|
| RATING | OPERATING TEMPERATURE RANGE | -35°C TO +85°C (NOTES 1) | STORAGE TEMPERATURE RANGE | -10°C TO +60°C | |
| | VOLTAGE | 30V AC | APPLICABLE CONNECTOR | BM10*(0.8)-44DP-0.4V(*) | |
| | CURRENT | 0.3A | | | |
| SPECIFICATIONS | | | | | |
| ITEM | TEST METHOD | | REQUIREMENTS | QT | AT |
| CONSTRUCTION | | | | | |
| GENERAL EXAMINATION | CONFIRMED VISUALLY AND BY MEASURING INSTRUMENT. | | ACCORDING TO DRAWING. | X | X |
| MARKING | CONFIRMED VISUALLY. | | | X | X |
| ELECTRIC CHARACTERISTICS | | | | | |
| CONTACT RESISTANCE | 20mV AC OR LESS 1kHz, 1mA | | 100mΩ MAX. | X | - |
| INSULATION RESISTANCE | 100V DC. | | 50MΩ MIN. | X | - |
| VOLTAGE PROOF | 100V AC FOR 1 min. | | NO FLASHOVER OR BREAKDOWN. | X | - |
| MECHANICAL CHARACTERISTICS | | | | | |
| INSERTION AND WITHDRAWAL FORCES | MEASURED BY APPLICABLE CONNECTOR. | | INSERTION FORCE 45.4N MAX WITHDRAWAL FORCE 8.7N MIN | X | - |
| MECHANICAL OPERATION | 10 TIMES INSERTIONS AND WITHDRAWAL. | | ① CONTACT RESISTANCE: 100mΩ MAX. ② NO DAMAGE, CRACK OR LOOSENESS OF PARTS. | X | - |
| VIBRATION | FREQUENCY 10 TO 55 TO 10 Hz, APPROX 5min, SINGLE AMPLITUDE 0.75 mm, 10CYCLES, FOR 3 DIRECTIONS. | | ① NO ELECTRICAL DISCONTINUITY OF 1 μs. ② NO DAMAGE, CRACK OR LOOSENESS OF PARTS. | X | - |
| SHOCK | 490 m/s ² DURATION OF PULSE 11 ms AT 3 TIMES FOR 3 DIRECTIONS. | | ① NO ELECTRICAL DISCONTINUITY OF 1 μs. ② NO DAMAGE, CRACK OR LOOSENESS OF PARTS. | X | - |
| ENVIRONMENTAL CHARACTERISTICS | | | | | |
| RAPID CHANGE OF TEMPERATURE | TEMPERATURE -55 → +85 °C TIME 30 → 30 min UNDER 5 CYCLES. (RELOCATION TIME TO CHAMBER: WITHIN 2 ~3 MIN) | | ① CONTACT RESISTANCE: 100mΩ MAX. ② INSULATION RESISTANCE: 50MΩ MIN. ③ NO DAMAGE, CRACK OR LOOSENESS OF PARTS. | X | - |
| DAMP HEAT (STEADY STATE) | EXPOSED AT 40 ± 2 °C, 90 TO 95 %, 96 h. | | ① CONTACT RESISTANCE: 100mΩ MAX. ② INSULATION RESISTANCE: 25MΩ MIN. ③ NO DAMAGE, CRACK OR LOOSENESS OF PARTS. | X | - |
| SULPHUR DIOXIDE | EXPOSED IN 25 PPM FOR 96h, 25°C, 75%. (REFER TO JIS C 60068) | | ① CONTACT RESISTANCE: 100mΩ MAX. ② NO DAMAGE, CRACK OR LOOSENESS OF PARTS. | X | - |
| | | | | | |
| | COUNT | DESCRIPTION OF REVISIONS | DESIGNED | CHECKED | DATE |
|  | | | | | |
| REMARKS | | | APPROVED | KH. IKEDA | 10.01.05 |
| NOTE1: INCLUDE THE TEMPERATURE RISING BY CURRENT | | | CHECKED | TS. MIYAZAKI | 10.01.05 |
| Unless otherwise specified, refer to JIS C 5402 and IEC 60512 | | | DESIGNED | SH. HOSODA | 10.01.04 |
| | | | DRAWN | SH. HOSODA | 10.01.04 |
| Note QT:Qualification Test AT:Assurance Test X:Applicable Test | | | DRAWING NO. | | ELC4-318886-01 |
|  | SPECIFICATION SHEET | | PART NO. | BM10NB (0.8)-44DS-0.4V (51) | |
| | HIROSE ELECTRIC CO., LTD. | | CODE NO. | CL684-6109-5-51 |  1/1 |



DRAWING FOR REFERENCE: This is subject to change without notice

2010/05/15 03:09:18 CAROLL TRIBBLE

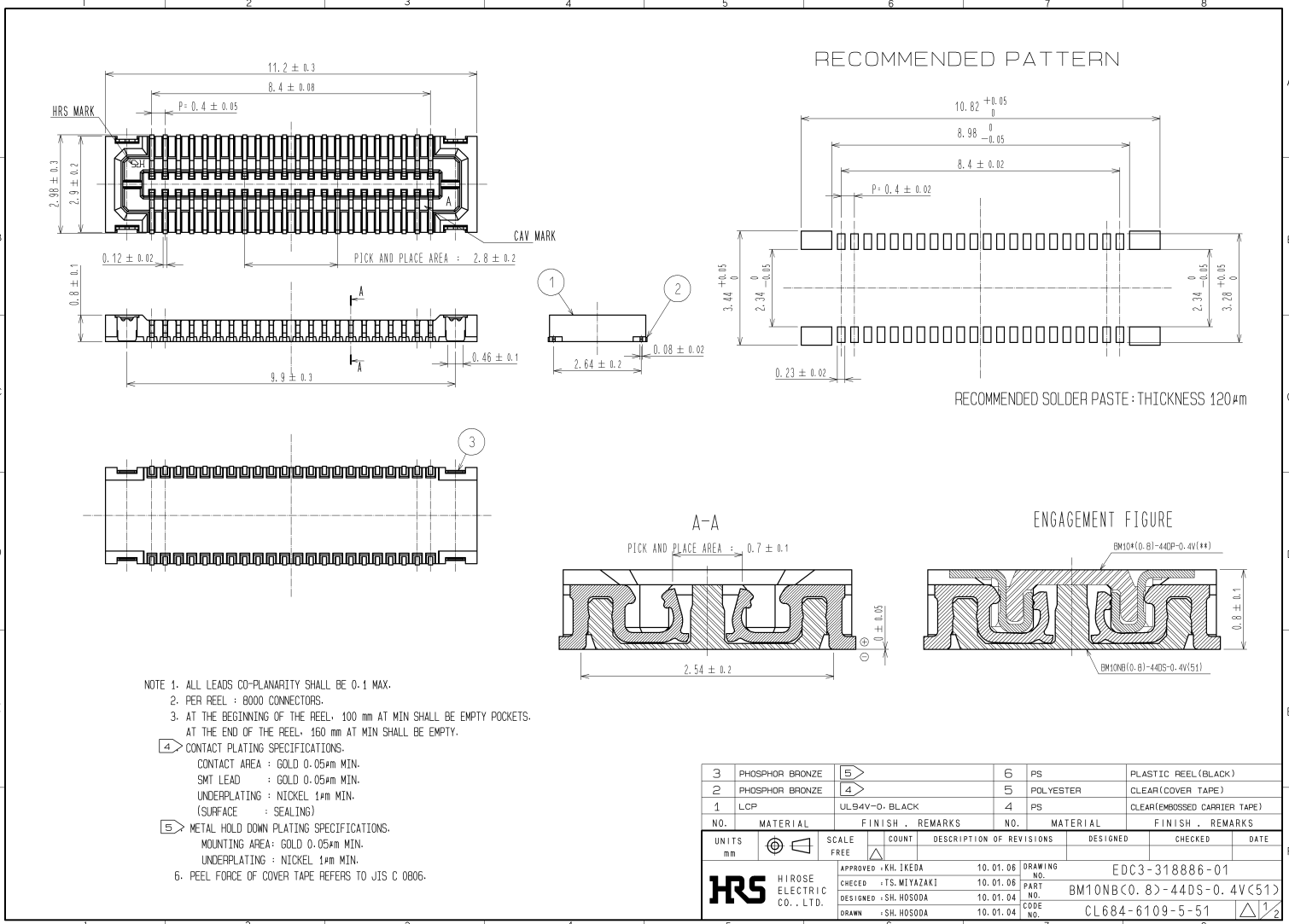
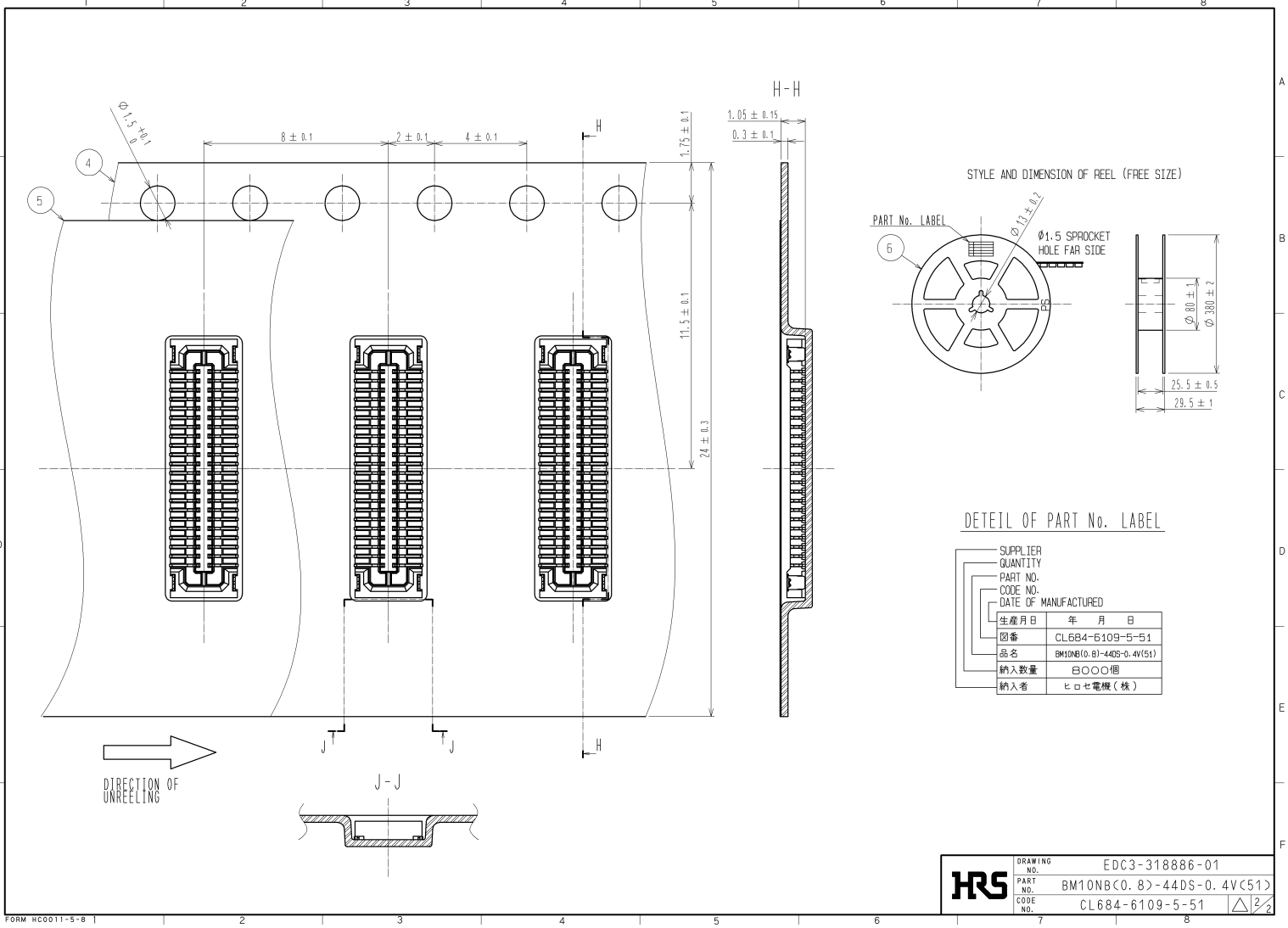

STYLE AND DIMENSION OF REEL (FREE SIZE)

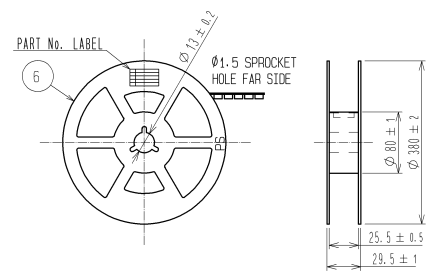

DETAIL OF PART No. LABEL

| | |
|----------------------|----------------------------|
| SUPPLIER | |
| QUANTITY | |
| PART NO. | |
| CODE NO. | |
| DATE OF MANUFACTURED | |
| 生産月日 | 年 月 日 |
| 図番 | CL684-6109-5-51 |
| 品名 | BM10NB(C. 8)-44DS-0.4V(S1) |
| 納入数量 | 8000個 |
| 納入者 | ヒロセ電機(株) |

| | | |
|------------|-------------|----------------------------|
| HRS | DRAWING NO. | EDC3-318886-01 |
| | PART NO. | BM10NB(C. 8)-44DS-0.4V(S1) |
| | CODE NO. | CL684-6109-5-51 |
| | | |

FORM HC0011-5-8 1

2

3

4

5

6

7

8