

RECOMMENDED PCB LAYOUT
(TOLERANCE: ±0.05mm)

RECOMMENDED PLUG DRAWING
SCALE: 2:1

- NOTES:
1. MATERIAL:
 - 1.1 HOUSING: COVER&SPACER
 - 1.2 HOUSING: BARRIER, J194V-0; COLOR: BLACK
 - 1.3 THERMOPLASTIC: U94V-0; COLOR: SEE TABLE
 - 1.4 SHELL: BRASS
 - 1.5 GROUND: BRASS
 - 1.6 TERMINAL: BRASS
 - 1.7 SPRING RING: PHOSPHOR BRONZE
 2. FINISH:
 - 2.1 T2T5: GOLD FLASH ON CONTACT AREA
 - 2.2 SPRING: 1U MIN. BRIGHT TIN PLATED ON SOLDER TAIL AREA, 50U MIN. NICKEL UNDERPLATED OVERALL.
 - 2.3 SHELL: 30U~80U BRIGHT TIN PLATING, 50U MIN. NICKEL UNDERPLATED OVERALL.
 - 2.4 GROUND: 100U MIN. BRIGHT TIN PLATING, 30U~80U NICKEL UNDER PLATING OVERALL.
 - 2.5 OTHER: 30~80U BRIGHT TIN PLATED ALL OVER, 80U NICKEL UNDER PLATING OVERALL.
 3. RECOMMENDED PCB THICKNESS: 1.60mm
 4. WAVE SOLDER CAPABLE TO 265°C
 5. PER TYCO SPEC. 109-202, CONDITION B.

TOLERANCES UNLESS OTHERWISE SPECIFIED:

0 PLC ± 0.3
2 PLC ± 0.2
3 PLC ± 0.2
ANGLES ± 3°

FINISH SEE NOTE

QUALIFICATION TEST REPORT

WEIGHT 19 GRAM

SCALE

LOC	SIZE	DRAWING NO	REV
DW	A3	C-1775824	A
SCALE	SHEET		1 OF 2

JACK BARREL COLOR	PART NUMBER
GRAY	1775824-2
BLACK	1775824-1
RED	
PINK	
70/C	
57/C	
284/C	
C	
B	
A	

DMN	S. HOU	20-APR-2006
CHK	W. J. KE	20-APR-2006
APVD	W. J. KE	20-APR-2006
PRODUCT SPEC	108-57377	
QUALIFICATION TEST REPORT	501-57409	
WEIGHT	19 GRAM	
LOC	SIZE	DRAWING NO
DW	A3	C-1775824
SCALE	SHEET	
	1 OF 2	

AUDIO JACK
TRIPLE STACKED
DIP TYPE

REVISION RECORD

REV	DESCRIPTION	DATE
A	REVISED	20-APR-2006
0	FIRST RELEASED	20-APR-2006
LTR	REVISION RECORD	20-APR-2006

SH	20-APR-2006
WK	2006
SH	20-APR-2006
WK	2006
DMN	CHK DATE

ECR-06-009162
FZ00-0332-04
EN

0 7 6 5 4 3 2 1

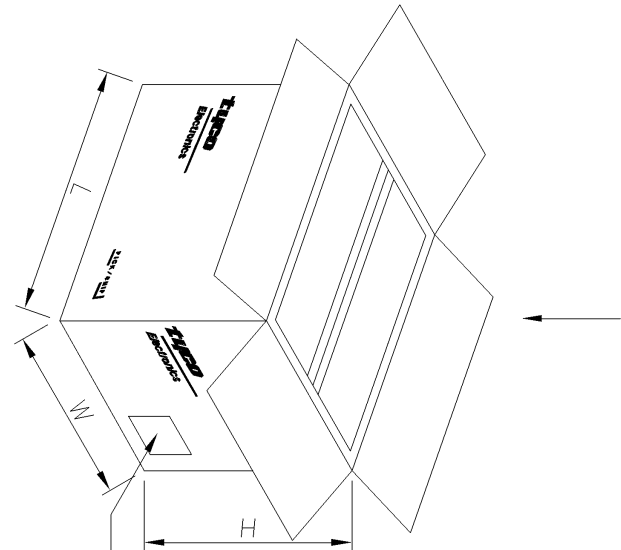
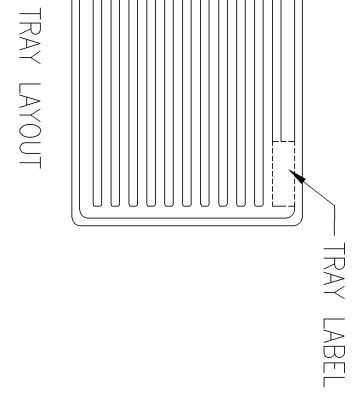
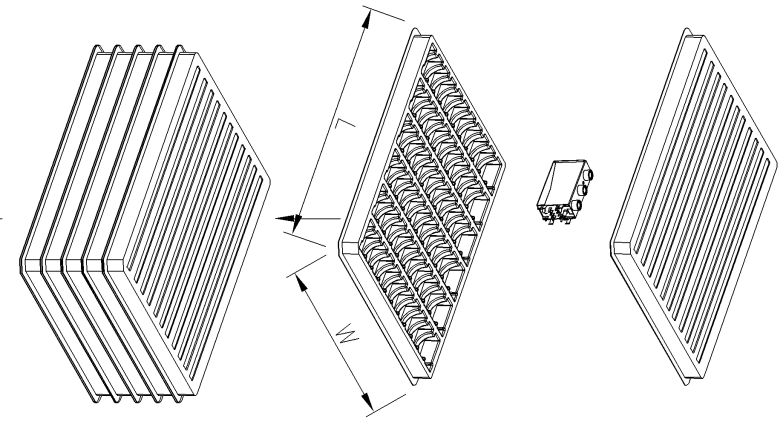
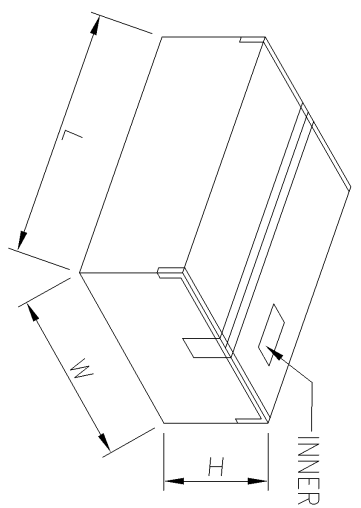

- NOTES :
1. MATERIAL :
 - 1.1 TRAY: PS WHITE
 - 1.2 INNER CARTON: CORRUGATED FIBERBOARD
 - 1.3 SHIPPING CARTON: CORRUGATED FIBERBOARD
 2. DIMENSION:
 - 2.1 TRAY: L=345mm, W=280mm, H=26mm
 - 2.2 INNER CARTON: L=350mm, W=285mm, H=155mm
 - 2.3 SHIPPING CARTON: L=365mm, W=300mm, H=335mm
 3. QUANTITY:
 - 3.1 PRIMARY PACKING: 66 PCS/TRAY
 - 3.2 SECONDARY PACKING: 5 TRAYS/INNER CARTON(330PCS)
 - 3.3 SECONDARY PACKING: 2 INNFERS/CARTON(660PCS)
 4. WEIGHT:
 - 4.1 NET WEIGHT: 12.5Kg
 - 4.2 GROSS WEIGHT: 14.5Kg

LTR	SEE SHEET 1	ECN	DWG	CHK	DATE
	REVISION RECORD				

FINISH		SEE NOTE		QUALIFICATION TEST REPORT		DOC. SIZE		DRAWING NO.		REV.	
MATERIAL		SEE NOTE		PRODUCT SPEC		SCALE		C-1775824		A	
TOLERANCES UNLESS OTHERWISE SPECIFIED:		DWN		S. HOU		NAME		tyco		TICO HOLDINGS (BERMUDA)	
0 PLC ±		CHK		20-APR-2006		W.J. KE		Electronics		VIII LTD. TAIWAN BRANCH	
2 PLC ±		APVD		20-APR-2006		W.J. KE		AUDIO JACK			
3 PLC ±		WGT		-		-		TRIPLE STACKED			
ANGLES #		WGT		-		-		DIP TYPE			

CUSTOMER DRAWING

A B C D