



**DLP-
USB232R**
LEAD-FREE

USB-SERIAL UART Module

The DLP-USB232R is DLP Design's smallest USB-to-serial UART interface module, and it utilizes the popular FT232R IC with the FTDIChip-ID™ feature from FTDI. In addition to enabling standard USB-to-serial designs, both asynchronous and synchronous bit-bang interface modes are available.

The internally-generated clock (6MHz, 12MHz, 24MHz and 48MHz) can be brought out of the module and used to drive a microcontroller or external logic.

The DLP-USB232R is available in a lead-free (RoHS compliant), compact 18-pin, 0.1-inch standard DIP footprint.

FEATURES:

- Single chip USB-to-asynchronous serial data-transfer interface.
- Entire USB protocol handled on the module; no USB-specific firmware programming is required.
- UART interface support for 7 or 8 data bits, 1 or 2 stop bits and odd/even/mark/space/no parity.
- Fully-assisted hardware or X-On/X-Off software handshaking.
- Data transfer rates from 300 baud to 3 megabaud (RS422/RS485 and TTL levels) and 300 baud to 1 Megabaud (RS232).
- 256-byte receive buffer and 128-byte transmit buffer utilizing buffer-smoothing technology to allow for high data throughput.
- FTDI's royalty-free VCP and D2XX drivers eliminate the need for USB driver development in most cases.
- Built-in support for event characters and line-break conditions.
- New USB FTDIChip-ID™ feature.
- New configurable CBUS I/O pins.
- Auto-transmit buffer control for RS485 applications.
- Transmit and receive LED drive signals.
- New 48MHz, 24MHz, 12MHz and 6MHz clock output signal options for driving an external MCU or FPGA.
- FIFO receive and transmit buffers for high data throughput.
- Adjustable receive buffer timeout.
- Synchronous and asynchronous bit-bang mode interface options with RD# and WR# strobes.
- New CBUS bit-bang mode option.

- Integrated 1024-bit internal EEPROM for storing USB VID, PID, serial number and product-description strings and CBUS I/O configuration.
- Module supplied preprogrammed with unique USB serial number.
- Support for USB Suspend and Resume.
- Support for bus-powered, self-powered and high-power bus-powered USB configurations.
- Integrated level converter on UART and CBUS for interfacing to 5V-1.8V logic.
- True 5V/3.3V/2.8V/1.8V CMOS drive output and TTL input.
- High I/O pin output drive option.
- Integrated power-on-reset circuit.
- UART signal-inversion option.
- USB bulk transfer mode.
- 3.3V to 5.25V single-supply operation.
- Low operating and USB Suspend current.
- Low USB bandwidth consumption.
- UHCI/OHCI/EHCI host-controller compatible.
- USB 2.0 full-speed compatible.
- -40°C to 85°C extended operating temperature range.
- Pb-free and RoHS compliant.

TYPICAL APPLICATIONS:

- USB to RS232/RS422/RS485 converters.
- Upgrading legacy peripherals to USB.
- Cellular and cordless phone USB data-transfer cables and interfaces.
- Interfacing MCU/PLD/FPGA-based designs to USB.
- USB audio and low-bandwidth video data transfer.
- PDA-to-USB data transfer.
- USB smart card readers.
- USB instrumentation.
- USB industrial control.
- USB MP3 player interface.
- USB FLASH card readers and writers.
- Set top box PC-USB interface.
- USB hardware modems.
- USB wireless modems.
- USB bar code readers.
- USB software and hardware encryption dongles.

DRIVER SUPPORT:

Royalty-Free Virtual COM Port (VCP) Drivers for:

- Windows 98, 98SE, ME, 2000, Server 2003, XP and Server 2008
- Windows XP and XP 64-bit
- Windows Vista and Vista 64-bit
- Windows XP Embedded
- Windows CE 4.2, 5.0 and 6.0

- Mac OS 8/9, OS-X
- Linux 2.4 and greater

Royalty-Free D2XX Direct Drivers (USB Drivers + DLL S/W Interface) for:

- Windows 98, 98SE, ME, 2000, Server 2003, XP and Server 2008
- Windows XP and XP 64-bit
- Windows Vista and Vista 64-bit
- Windows XP Embedded
- Windows CE 4.2, 5.0 and 6.0
- Linux 2.4 and greater

Note: The drivers listed above are all available for free download from the DLP Design website www.dlpdesign.com and the FTDI website www.ftdichip.com

Various third-party drivers are also available for other operating systems; see the FTDI website www.ftdichip.com for details.

ABSOLUTE MAXIMUM RATINGS

- | | |
|---|---------------------|
| • Storage Temperature | -65°C to +150°C |
| • Ambient Temperature (Power Applied) | -40°C to +85°C |
| • VCC Supply Voltage | -0.5V to +6.00V |
| • DC Input Voltage: High-Impedance Bidirectionals | -0.5V to VCC + 0.5V |
| • DC Output Current: Outputs | 24mA |
| • DC Output Current: Low-Impedance Bidirectionals | 24mA |
| • Electrostatic Discharge Voltage (I<1uA) | +/- 2000V |
| • Latch Up Current (Vi<0 or Vi>Vcc) | 100mA |

D.C. CHARACTERISTICS (AMBIENT TEMPERATURE = -40°C TO +85°C)

- | | |
|----------------------------------|-------------------------|
| • VCC Operating-Supply Voltage | 4.0 - 5.25V |
| • VCCIO Operating-Supply Voltage | 4.0 - 5.25V |
| • Operating Supply Current | 15mA (Normal Operation) |
| • Operating Supply Current | 100uA USB Suspend |

PINOUT DESCRIPTION

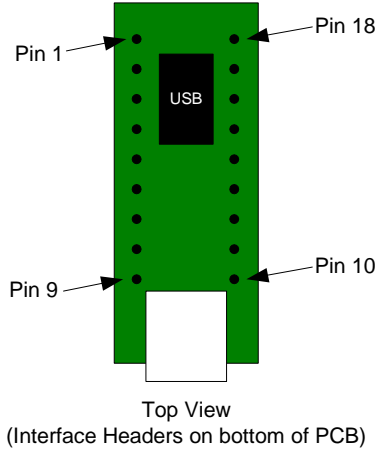

PIN #	DESCRIPTION
1	GROUND
2	RTS - Request to Send Control Output/Handshake Signal
3	RI - Ring Indicator Control Input. When remote wake-up is enabled in the internal EEPROM taking RI# low (20ms active low pulse), this can be used to resume the PC USB host controller from Suspend.
4	DSR - Data Set Ready Control Input/Handshake Signal
5	CTS - Clear To Send Control Input/Handshake Signal
6	CBUS4 - Configurable CBUS output-only pin. The function of this pin is configured in the FT232R internal EEPROM (see CBUS Signal Options in the next section).
7	VCCIO - +1.8V to +5.25V supply for the UART interface and CBUS group (Pins 6, 11, 12, 14 and 15). Connect this pin to an external power supply to drive out at +3.3V levels (or another voltage within the specified range), or connect to EXTVCC (Pin 8) to drive out at the +5V CMOS level.
8	EXTVCC - Use for applying main power (4.0 to 5.25 volts) to the module. Connect to PORTVCC (Pin 9) if the module is to be powered by the USB port (typical configuration).
9	PORTVCC - Power from the USB port. Connect to EXTVCC (Pin 8) if the module is to be powered by the USB port (typical configuration). 500mA is the maximum current available to the USB adapter and target electronics if the USB device is configured for high power.
10	GROUND
11	CBUS2 - Configurable CBUS I/O pin. The function of this pin is configured in the FT232R internal EEPROM (see CBUS Signal Options in the next section).
12	CBUS3 - Configurable CBUS I/O Pin. The function of this pin is configured in the FT232R internal EEPROM (see CBUS Signal Options in the next section).
13	DCD - Data Carrier Detect Control Input
14	CBUS1 - Configurable CBUS I/O Pin. The function of this pin is configured in the FT232R internal EEPROM (see CBUS Signal Options in the next section).
15	CBUS0 - Configurable CBUS I/O Pin. The function of this pin is configured in the FT232R internal EEPROM (see CBUS Signal Options in the next section).
16	RXD - Receiving Asynchronous Data Input
17	DTR - Data Terminal Ready Control Output/Handshake Signal
18	TXD - Transmit Asynchronous Data Output

CBUS SIGNAL OPTIONS

The following options can be configured on the CBUS I/O pins in the internal EEPROM using the software utility MPROG, which can be downloaded from www.dlpdesign.com:

CBUS SIGNAL OPTION	AVAILABLE ON CBUS PIN	DESCRIPTION
TXDEN#	CBUS0, CBUS1, CBUS2, CBUS3, CBUS4	Enable transmit data for RS485.
PWREN#	CBUS0, CBUS1, CBUS2, CBUS3, CBUS4	This output is low after the module has been configured by USB, then high during USB Suspend Mode. This output can be used to control power to an external P-channel logic-level MOSFET switch. Enable the interface pull-down option when using the PWREN# in this way.*
TXLED#	CBUS0, CBUS1, CBUS2, CBUS3, CBUS4	Transmit data LED drive; pulses low when transmitting data via USB.
RXLED#	CBUS0, CBUS1, CBUS2, CBUS3, CBUS4	Receive data LED drive; pulses low when receiving data.
TX&RXLED#	CBUS0, CBUS1, CBUS2, CBUS3, CBUS4	LED drive; pulses low when transmitting or receiving data.
SLEEP#	CBUS0, CBUS1, CBUS2, CBUS3, CBUS4	Goes low during USB Suspend Mode. Typically used to power down an external TTL-to-RS232 level converter IC in USB-to-RS232 converter designs.
CLK48	CBUS0, CBUS1, CBUS2, CBUS3, CBUS4	48MHz clock output**
CLK24	CBUS0, CBUS1, CBUS2, CBUS3, CBUS4	24MHz clock output**
CLK12	CBUS0, CBUS1, CBUS2, CBUS3, CBUS4	12MHz clock output**
CLK6	CBUS0, CBUS1, CBUS2, CBUS3, CBUS4	6MHz clock output**

CBitBangI/O	CBUS0, CBUS1, CBUS2, CBUS3	CBUS bit-bang mode option. Allows up to four of the CBUS pins to be used as general purpose I/O. Configured individually for CBUS0, CBUS1, CBUS2 and CBUS3 in the internal EEPROM. [A separate Application Note (AN232R-01, available from the FTDI website (www.ftdichip.com)) describes in more detail how to use the CBUS bit-bang mode.]
BitBangWRn	CBUS0, CBUS1, CBUS2, CBUS3	Synchronous and asynchronous bit-bang mode WR# strobe output.
BitBangRDn	CBUS0, CBUS1, CBUS2, CBUS3	Synchronous and asynchronous bit-bang mode RD# strobe output.

* *PWREN# should be used with a 10k-ohm resistor pull-up.*

** *When in USB Suspend Mode, the output clocks are also suspended.*

1.0 QUICK START GUIDE

Note: This guide requires the use of a Windows 98/2000/Vista PC that is equipped with a USB port.

1. Download the CDM drivers from either www.dlpdesign.com or www.ftdichip.com. Unzip the drivers into a folder on the hard drive.
2. Select a power source for the DLP-USB232R. The typical configuration for an all 5-volt system is to connect Pins 7, 8 and 9.
3. Connect the DLP-USB232R module to the host PC via a USB-A to Mini-B cable. This action initiates the loading of USB drivers. When prompted, select the folder where the CDM drivers were stored in Step 1. Windows will then complete the installation of the device drivers for the DLP-USB232R module. The next time the DLP-USB232R module is attached, the host PC will immediately load the correct drivers without any prompting. Reboot the PC if prompted to do so.

At this point, the DLP-USB232R is ready for use.

Note: If an extra COM port is not available after installing the CDM drivers, connect the DLP-USB232R and open Control Panel>System>Device Manager. Right click on USB Serial Converter under USB Controllers and select Properties, then the Advanced tab. Check the box marked Load VCP, and then click OK. Unplug and re-plug the DLP-USB232R, and a COM port will be added. [This method is also used to convert from VCP drivers to the D2XX (DLL) drivers.]

2.0 DEVICE CONFIGURATION EXAMPLES

USB Bus-Powered and Self-Powered Configurations

Figure 1.

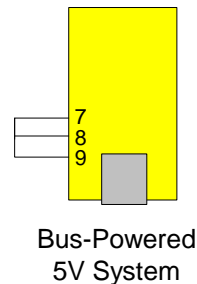

The figure above illustrates a typical USB bus-powered configuration. A USB bus-powered device gets its power from the USB bus. Basic rules for USB bus-powered devices are as follows:

1. On plug-in to USB, the module and external circuitry should draw no more than 100mA on the 5-volt line from the USB host.
2. In USB Suspend Mode, the module and external circuitry should draw no more than 2.5mA.
3. A bus-powered, high-power USB device (one that draws more than 100mA) should use one of the CBUS pins configured as PWREN# to keep the current below 100mA on plug-in and below 2.5mA on USB Suspend.
4. A design that consumes more than 100mA in total cannot be plugged into a USB bus-powered hub.
5. No USB target system can draw more than 500mA from the USB bus. The power descriptors in the internal EEPROM of the FT232R should be programmed to match the total current drawn by the target system.

Note: If using PWREN# (available using the CBUS), the I/O pin should be pulled to VCCIO using a 10k-ohm resistor.

Figure 2.

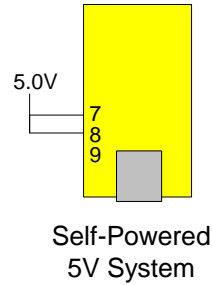

Figure 2 illustrates a typical USB self-powered configuration. A USB self-powered device gets its power from its own power supply and does not draw current from the USB bus. Basic rules for USB self-powered devices are as follows:

1. A self-powered device should not force current down the USB bus when the USB host or hub controller is powered down.
2. A self-powered device can take as much current as it likes during normal operation and during USB Suspend as it has its own power supply.
3. A self-powered device can be used with any USB host and both bus- and self-powered USB hubs.

Figure 3.

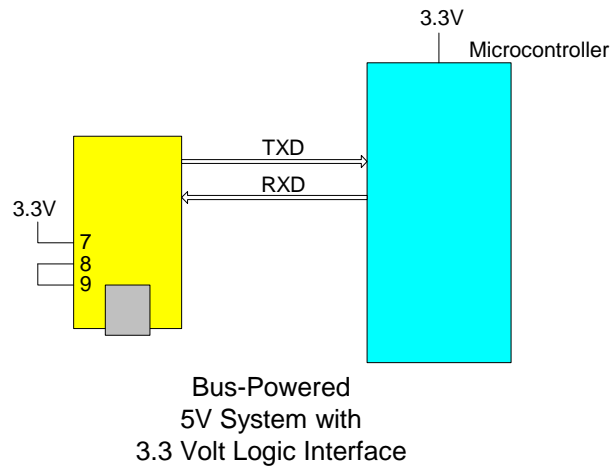
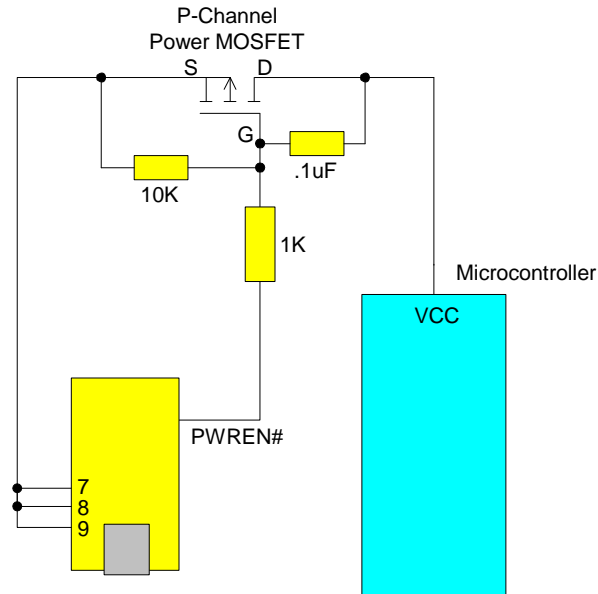

Figure 3 shows how to configure the DLP-USB232R to interface with a 3.3V logic device. In this example, the target electronics provide the 3.3 volts via the VCCIO line (Pin 7) which, in turn, will cause the FT232R interface I/O pins to drive out at the 3.3V level.

Bus-Powered Circuit with Power Control

USB bus-powered circuits need to be able to power down in USB Suspend Mode in order to meet the $\leq 2.5\text{mA}$ total suspend current requirement (including external logic):

Figure 4.



Power Controlled by
PWREN#

Figure 4 shows how to use a discrete P-Channel MOSFET to control the power to external logic circuits. This “soft-start” circuit accommodates designs that draw more than 100mA at power up.

Please note the following points in connection with power-controlled designs:

1. The logic to be controlled must have its own reset circuitry so that it will automatically reset itself when power is reapplied on coming out of Suspend.
2. Set the soft pull-down option bit in the FT232R EEPROM.
3. For USB high-power, bus-powered applications (ones that consume greater than 100mA, and up to 500mA of current from the USB bus), the power consumption of the application must be set in the Max Power Field in the internal FT232R EEPROM. A high-power, bus-powered application uses the descriptor in the internal FT232R EEPROM to inform the system of its power requirements.
4. PWREN# gets its VCC from VCCIO. For designs using 3.3-volt logic, ensure that VCCIO is not powered down during Suspend.

3.0 MECHANICAL DRAWING (PRELIMINARY) INCHES (MILLIMETERS) UNLESS OTHERWISE NOTED

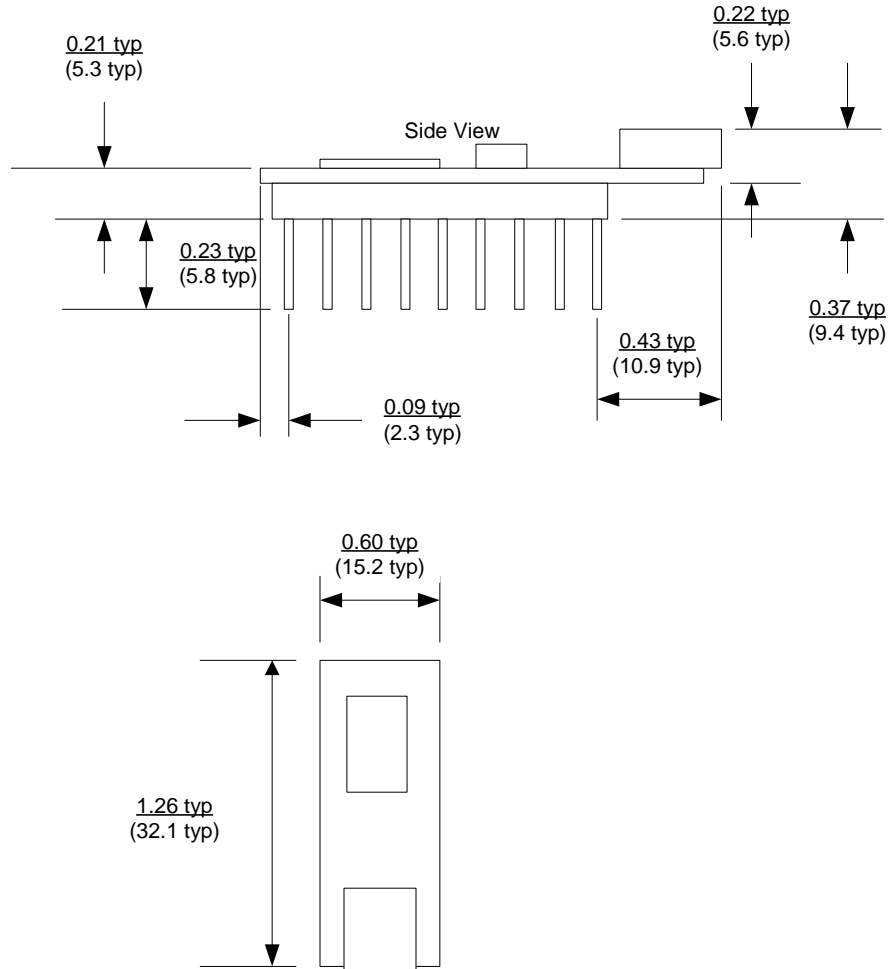

4.0 DISCLAIMER

© DLP Design, Inc., 2008

Neither the whole nor any part of the information contained herein nor the product described in this manual may be adapted or reproduced in any material or electronic form without the prior written consent of the copyright holder.

This product and its documentation are supplied on an as-is basis, and no warranty as to their suitability for any particular purpose is either made or implied. DLP Design, Inc. will not accept any claim for damages whatsoever arising as a result of the use or failure of this product. Your statutory rights are not affected. This product or any variant of it is not intended for use in any medical appliance, device or system in which the failure of the product might reasonably be expected to result in personal injury.

This document provides preliminary information that may be subject to change without notice.

5.0 CONTACT INFORMATION

DLP Design, Inc.
1605 Roma Lane
Allen, TX 75013

Phone: 469-964-8027
Fax: 415-901-4859

Email Sales: sales@dlpdesign.com
Email Support: support@dlpdesign.com
Website URL: <http://www.dlpdesign.com>

DLP DESIGN

DLP-USB232R

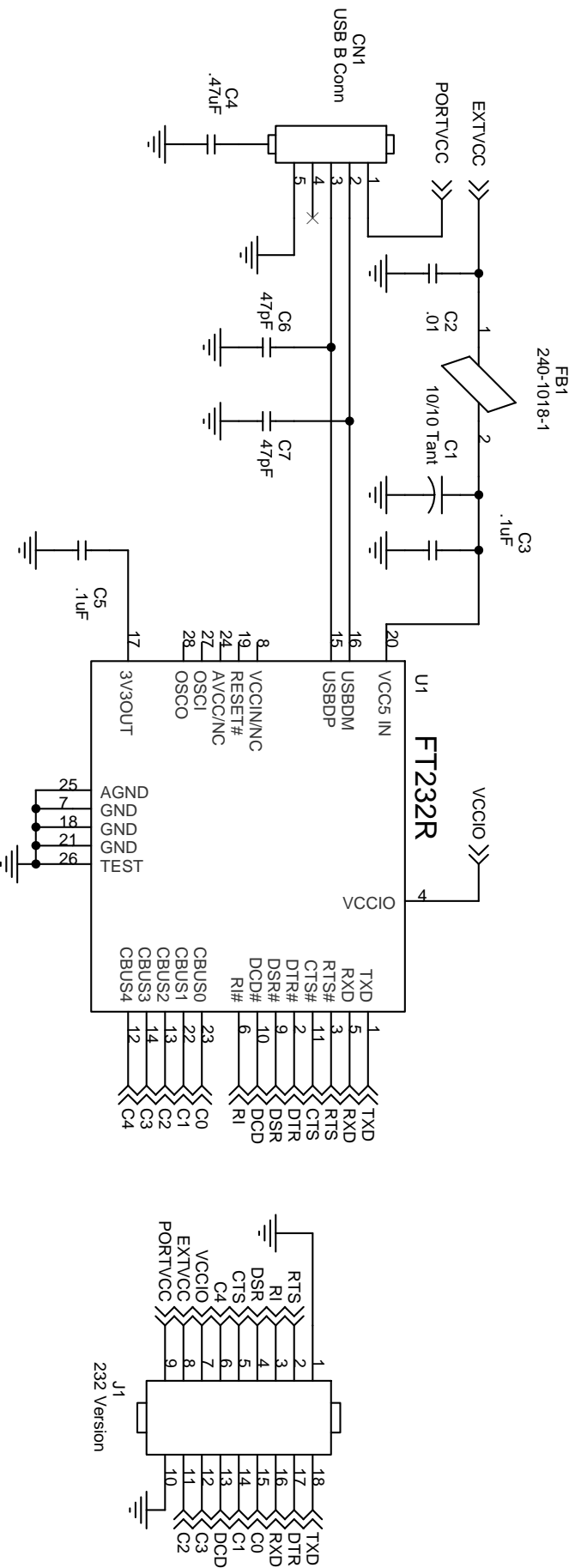

5

4

3

2

1

5

4

3

2

1