

THIS DRAWING IS UNPUBLISHED
 UNLESS OTHERWISE SPECIFIED
 ALL RIGHTS RESERVED

REV	DATE	DESCRIPTION	BY	CHK	APP
AD	25				
C		REVISED PER ECO-05-01584			

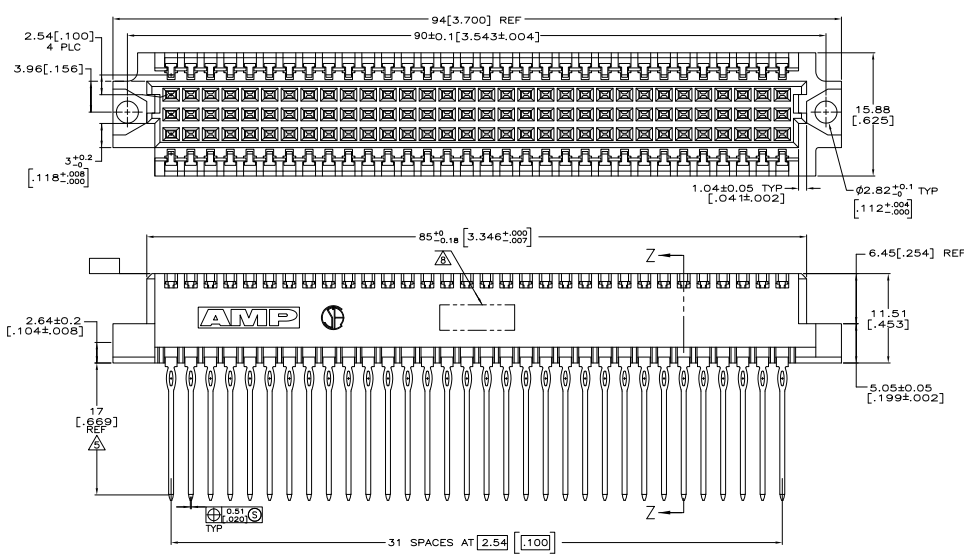

- △ HOUSING MATERIAL: GLASS-FILLED POLYESTER. COLOR: GRAY.
- △ CONTACT MATERIAL: PHOSPHOR BRONZE.
- △ CONTACT FINISH: DIN 41612 CLASS 2 IN CONTACT AREA AND LAST 5.08 [200] OF THE TAILS.
- △ ACTION PIN POSTS REQUIRE 1.57 [062] MINIMUM THICK PC BOARD. RECOMMENDED PC BOARD DRILLED HOLES ARE Ø1.54 ± 0.025 [0.453 ± 0.010] WITH 0.02-0.08 [001-003] COPPER AND 0.008 [0003] MINIMUM TIN-LEAD PLATING. FINISHED HOLE AFTER PLATING IS Ø1.02 ± 0.08 [0.40 ± 0.002].
- △ TAIL LENGTH AFTER SEATED IN PC BOARD.
- △ CONTACT POINTS AFTER SEATED IN PC BOARD.
- △ HOT-STAMPING ON THIS SIDE.
- △ PART NUMBER AND DATE CODE HOT-STAMPED IN THIS APPROXIMATE AREA.

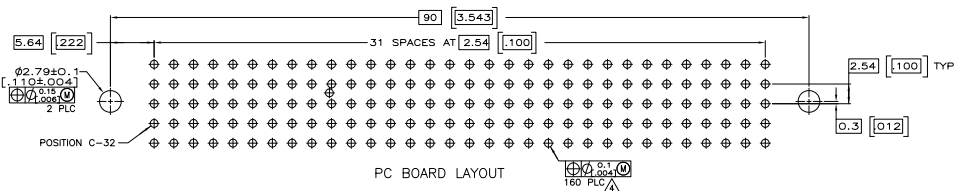
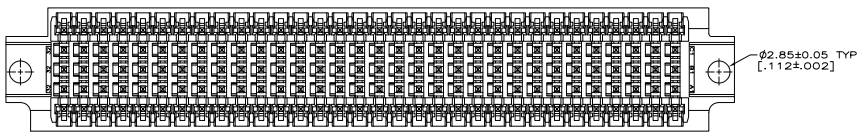
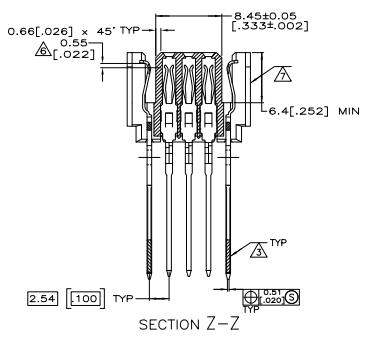

THIS DRAWING IS A CONTROLLED DOCUMENT		DATE		REVISION		PART NUMBER	
DESIGNED BY	REVISIONS	DATE	DESCRIPTION	BY	CHK	APP	
R. PATTERSON			RCPT ASSY, ENHANCED EUROCARD, VME 64, 160 POSITION				1-148445-5
DATE	DATE	DATE	DATE	DATE	DATE	DATE	DATE
CUSTOMER DRAWING		A100779G=148445		TABLE 4-1		PAGE 1 OF 1	