

This drawing involves proprietary design rights of Tyco Electronics Corporation, and all design, manufacture, reproduction, use and sale rights regarding the same are expressly reserved. It is submitted for a specific purpose and the recipient by accepting this drawing, assumes custody and control and agrees to take reasonable precautions: (a) that this drawing will not be copied and reproduced, in whole or in part, or its contents revealed in any manner, or to any person except to meet the purpose for which it was delivered and (b) that any special features peculiar to this design will not be incorporated in other projects without the expressed written permission of Tyco Electronics Corporation.

REVISIONS			
EC	REV	DESCRIPTION	DATE
—	A	NEW RELEASE	06/15/05

NOTES: UNLESS OTHERWISE SPECIFIED;

1. PART NUMBER CHANGES AND OR DESIGN CHANGES AFFECTING ITEM INTERCHANGEABILITY REQUIRE PRIOR ELCON APPROVAL AND AUTHORIZATION BY REVISION TO THIS DRAWING.

2. MATERIALS:

INSULATORS: THERMOPLASTIC, GLASS REINFORCED, COLOR-BLACK, UL94V-0 FLAMMABILITY RATED.

POWER CONTACTS: PHOSPHOR BRONZE ALLOY COPPER ALLOY

CROWN BANDS: BERYLLIUM COPPER ALLOY

3. FINISHES:

CONTACTS: SELECTIVE GOLD PER MIL-G-45204, TYPE II, CLASS 0, .000030" MIN. THK, OVER NICKEL PER QQ-N-290, CLASS 2, .000050" MIN. THICK.

PCB TERMINATION: TIN PLATED PER ASTM B-545, .000120" MIN THICK OVER NICKEL PER QQ-N-290

4. ITEMS PROVIDED TO THIS SPECIFICATION TO BE PERMANENTLY IDENTIFIED PER THE FOLLOWING IDENTIFIER:

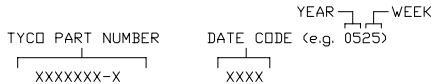

5. SEE DRAWING C-6646440, C-6646441 FOR MATING SOCKET CONNECTOR.

6. CONNECTOR INFORMATION

CONNECTOR	TYCO PART NUMBER	CATALOG MODULE #	TYPE	SIZE NO.	CONTACT QTY	MATING PIN	MAX CURRENT (PER CONTACT)	CONTACT SPACING	VOLTAGE RATING*
PIN	6648099-1	FP0815	DEDICATED HOUSING	8	3	1.25 X 7.00 [.049 X .276]	35 AMPERES	7.50 [2953]	250 VOLTS

*IAW IEC-950

<p>THIRD ANGLE PROJECTION</p> <p>UNLESS OTHERWISE SPECIFIED DIMENSIONS ARE IN METRIC (INCHES)</p> <p>TOLERANCES</p> <p>ANGLES ± .5°</p> <p>DECIMALS</p> <p>.XX ± .25 [.010]</p> <p>.X ± .5 [.020]</p>	DRAWN	M.C.CANT/H. NGUYEN	DATE	06/04/05	Tyco Electronics Corporation Menlo Park, Ca 94025 			
	CHECKED		TITLE	CONNECTOR, PIN, RIGHT ANGLE STANDARD SOLDER TAILS ONE-PIECE BLADE, FLATPAQ				
	APPROVED		SIZE	B	DWG NUMBER	C = 6648099	REV.	A
	APPROVED	D. CHAU	DATE	06/28/05	ACAD FILE NUMBER	C6648099A.DWG	DWG SCALE	1=1

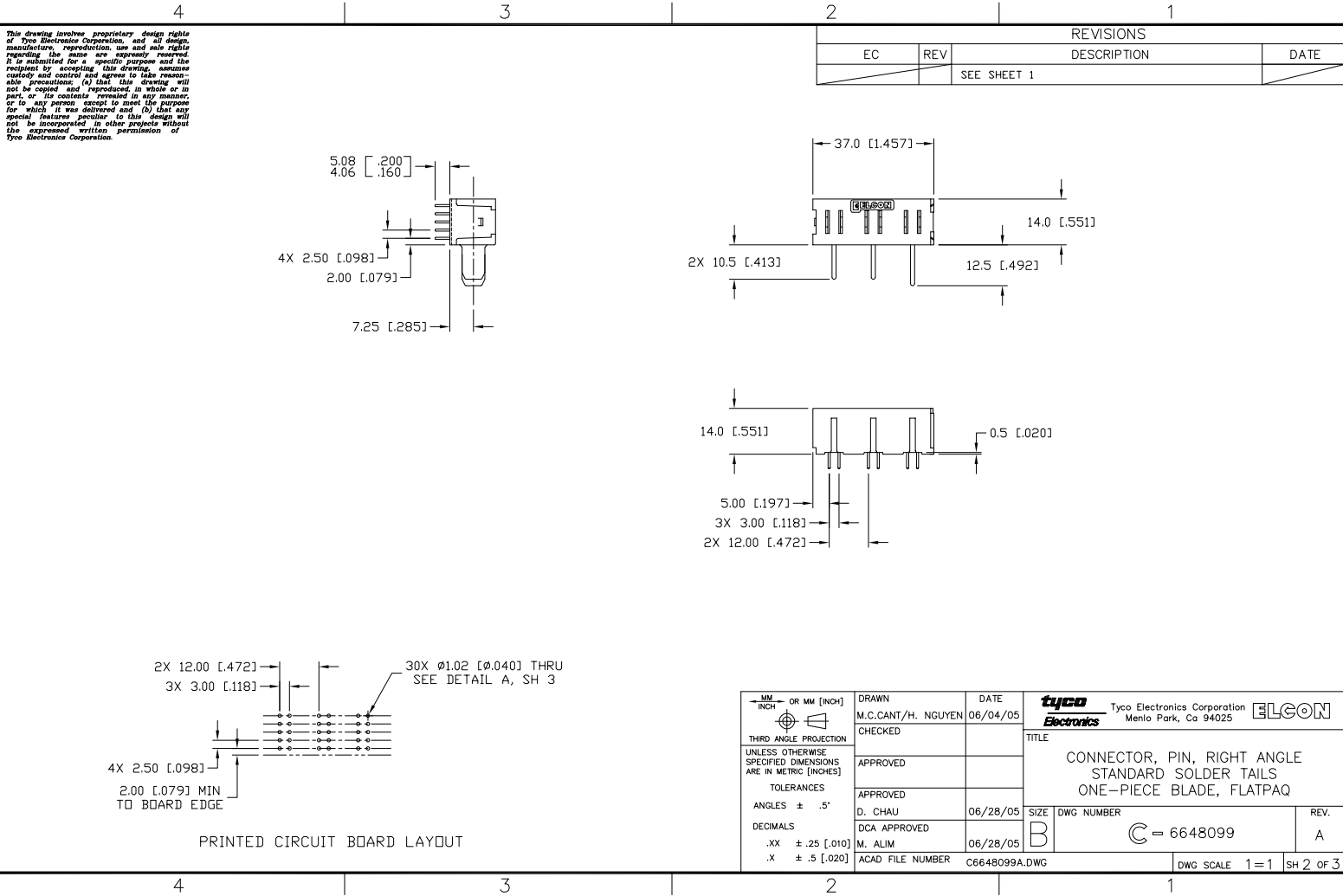

This drawing involves proprietary design rights of Tyco Electronics Corporation, and all design, manufacture, reproduction, use and sale rights regarding the same are expressly reserved. It is submitted for a specific purpose and the recipient by accepting this drawing, assumes custody and control and agrees to take reasonable precautions: (a) that this drawing will not be copied and reproduced, in whole or in part, or its contents revealed in any manner, or to any person except to meet the purpose for which it was delivered and (b) that any special features peculiar to this design will not be incorporated in other projects without the expressed written permission of Tyco Electronics Corporation.

REVISIONS			
EC	REV	DESCRIPTION	DATE
		SEE SHEET 1	

PRINTED CIRCUIT BOARD LAYOUT

MM OR MM [INCH] THIRD ANGLE PROJECTION UNLESS OTHERWISE SPECIFIED DIMENSIONS ARE IN METRIC [INCHES] TOLERANCES ANGLES ± .5° DECIMALS .XX ± .25 [.010] .X ± .5 [.020]	DRAWN M.C.CANT/H. NGUYEN CHECKED APPROVED APPROVED D. CHAU DCA APPROVED M. ALIM ACAD FILE NUMBER C6648099A.DWG	DATE 06/04/05 06/28/05 06/28/05	 Tyco Electronics Corporation Menlo Park, Ca 94025 TITLE CONNECTOR, PIN, RIGHT ANGLE STANDARD SOLDER TAILS ONE-PIECE BLADE, FLATPAQ SIZE DWG NUMBER B C = 6648099 REV. A	DWG SCALE 1=1 SH 2 OF 3
---	---	--	--	-------------------------------

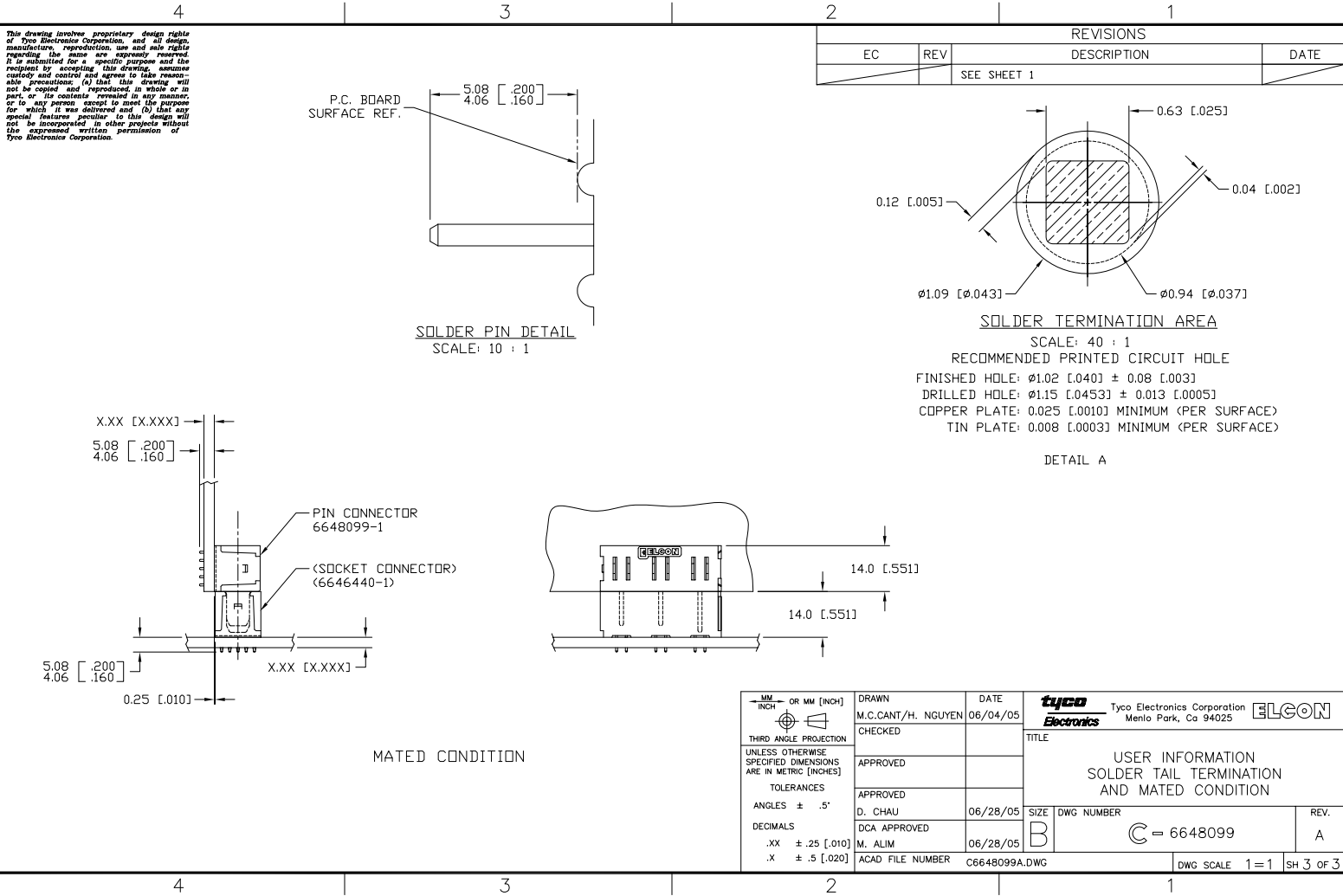

This drawing involves proprietary design rights of Tyco Electronics Corporation, and all design, manufacture, reproduction, use and sale rights regarding the same are expressly reserved. It is submitted for a specific purpose and the recipient by accepting this drawing, assumes custody and control and agrees to take reasonable precautions: (a) that this drawing will not be copied and reproduced, in whole or in part, or its contents revealed in any manner, or to any person except to meet the purpose for which it was delivered and (b) that any special features peculiar to this design will not be incorporated in other projects without the expressed written permission of Tyco Electronics Corporation.

MM OR MM [INCH] THIRD ANGLE PROJECTION UNLESS OTHERWISE SPECIFIED DIMENSIONS ARE IN METRIC [INCHES] TOLERANCES ANGLES \pm .5' DECIMALS .XX \pm .25 [0.010] .X \pm .5 [0.020]	DRAWN M.C.CANT/H. NGUYEN CHECKED APPROVED APPROVED D. CHAU DCA APPROVED M. ALIM ACAD FILE NUMBER C6648099A.DWG	DATE 06/04/05 06/28/05 06/28/05	tyco Tyco Electronics Corporation Electronics Menlo Park, Ca 94025 ELCON TITLE USER INFORMATION SOLDER TAIL TERMINATION AND MATED CONDITION SIZE DWG NUMBER B C = 6648099 REV. A
DWG SCALE 1=1 SH 3 OF 3			