

REV	DATE	DESCRIPTION	BY	CHK	APP
AD 00					
NS		REVISED PER EDD-11-004835			

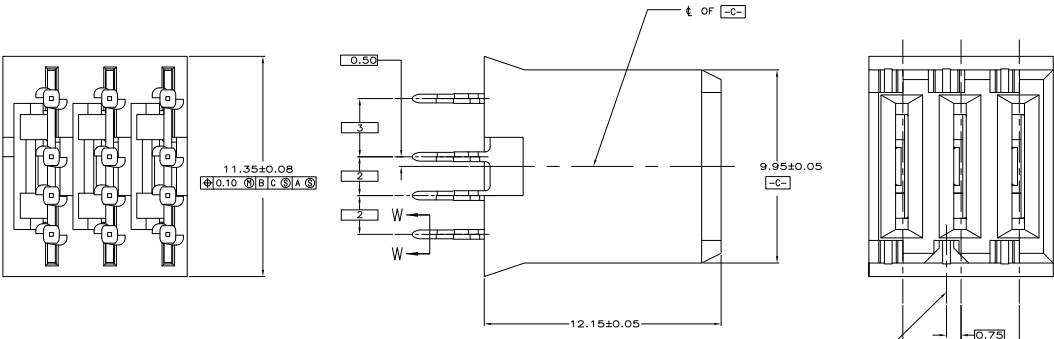

- △ MATERIAL: HOUSING: POLYESTER, COLOR: GRAY, UL 94V-0. CONTACT: PHOSPHOR BRONZE.
 - △ FINISH: CONTACT MATING AREA: 1.27µm MIN GOLD OR 0.08µm MIN GOLD OVER 0.76µm MIN PALLADIUM-NICKEL. ACTION FINI AREA: 0.5µm MIN TIN LEAD PLATE, ALL OVER 1.27µm MIN NICKEL UNDERPLATE.
 - △ FINISH: CONTACT LUBRICATION WITH BELLCORE APPROVED LUBRICANT, TECHNICAL REFERENCE: TR-NWT-001217 ISSUE 1, SEPT 1992.
 - △ TOLERANCE TO BE ±0.28 AFTER CONNECTOR IS APPLIED TO PC BOARD.
 - △ RESTRICTED PART NUMBER, CONTACT ENGINEER.
 - △ MATERIAL: HOUSING: POLYESTER, COLOR: GRAY, UL 94V-0. CONTACT: HIGH CURRENT COPPER ALLOY.
 - △ REFERENCE APPLICATION SPEC 114-1103 FOR RECOMMENDED PLATED THRU HOLE DIAMETER AND PLATING THICKNESSES.
8. CURRENT RATING 10A/CONTACT FOR PHOS BRONZE CONTACTS AND 16A/CONTACT FOR HIGH CURRENT COPPER ALLOY CONTACTS PER PRODUCT SPEC 108-1651

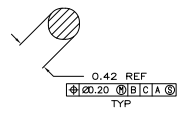
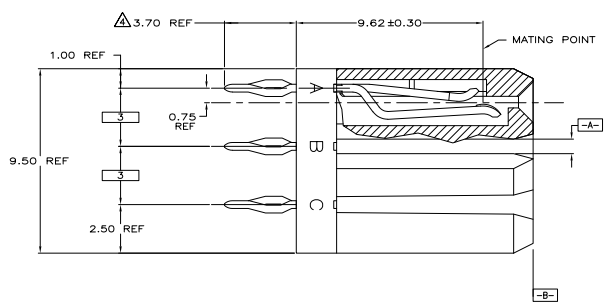

SECTION W-W
 SCALE 40:1

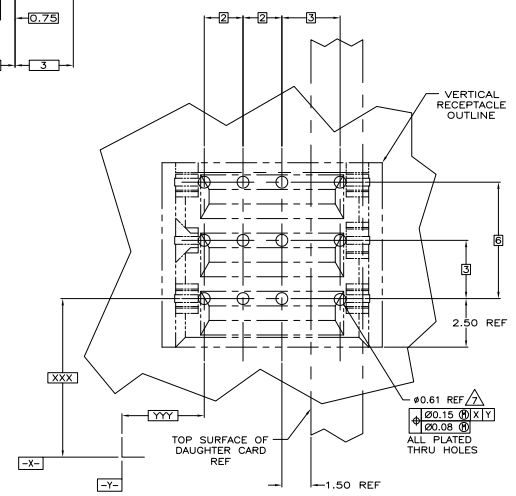

RECOMMENDED PCB HOLE LAYOUT

MATERIAL	FINISH	PART NUMBER
△	△	5-223955-2
△	△	223955-8
△	△	223955-2

THIS DRAWING IS A CONTROLLED DOCUMENT		REV	DATE	BY	CHK	APP
DESIGNED	DESIGNED					
DRAWN	DRAWN					
CHECKED	CHECKED					
APPROVED	APPROVED					
DATE	DATE					
BY	BY					
CHK	CHK					
APP	APP					
REV	REV					
DATE	DATE					
BY	BY					
CHK	CHK					
APP	APP					
REV	REV					
DATE	DATE					
BY	BY					
CHK	CHK					
APP	APP					
REV	REV					
DATE	DATE					
BY	BY					
CHK	CHK					
APP	APP					
REV	REV					
DATE	DATE					
BY	BY					
CHK	CHK					
APP	APP					
REV	REV					
DATE	DATE					
BY	BY					
CHK	CHK					
APP	APP					
REV	REV					
DATE	DATE					
BY	BY					
CHK	CHK					
APP	APP					
REV	REV					
DATE	DATE					
BY	BY					
CHK	CHK					
APP	APP					
REV	REV					
DATE	DATE					
BY	BY					
CHK	CHK					
APP	APP					
REV	REV					
DATE	DATE					
BY	BY					
CHK	CHK					
APP	APP					
REV	REV					
DATE	DATE					
BY	BY					
CHK	CHK					
APP	APP					
REV	REV					
DATE	DATE					
BY	BY					
CHK	CHK					
APP	APP					
REV	REV					
DATE	DATE					
BY	BY					
CHK	CHK					
APP	APP					
REV	REV					
DATE	DATE					
BY	BY					
CHK	CHK					
APP	APP					
REV	REV					
DATE	DATE					
BY	BY					
CHK	CHK					
APP	APP					
REV	REV					
DATE	DATE					
BY	BY					
CHK	CHK					
APP	APP					
REV	REV					
DATE	DATE					
BY	BY					
CHK	CHK					
APP	APP					
REV	REV					
DATE	DATE					
BY	BY					
CHK	CHK					
APP	APP					
REV	REV					
DATE	DATE					
BY	BY					
CHK	CHK					
APP	APP					
REV	REV					
DATE	DATE					
BY	BY					
CHK	CHK					
APP	APP					
REV	REV					
DATE	DATE					
BY	BY					
CHK	CHK					
APP	APP					
REV	REV					
DATE	DATE					
BY	BY					
CHK	CHK					
APP	APP					
REV	REV					
DATE	DATE					
BY	BY					
CHK	CHK					
APP	APP					
REV	REV					
DATE	DATE					
BY	BY					
CHK	CHK					
APP	APP					
REV	REV					
DATE	DATE					
BY	BY					
CHK	CHK					
APP	APP					
REV	REV					
DATE	DATE					
BY	BY					
CHK	CHK					
APP	APP					
REV	REV					
DATE	DATE					
BY	BY					
CHK	CHK					
APP	APP					
REV	REV					
DATE	DATE					
BY	BY					
CHK	CHK					
APP	APP					
REV	REV					
DATE	DATE					
BY	BY					
CHK	CHK					
APP	APP					
REV	REV					
DATE	DATE					
BY	BY					
CHK	CHK					
APP	APP					
REV	REV					
DATE	DATE					
BY	BY					
CHK	CHK					
APP	APP					
REV	REV					
DATE	DATE					
BY	BY					
CHK	CHK					
APP	APP					
REV	REV					
DATE	DATE					
BY	BY					
CHK	CHK					
APP	APP					
REV	REV					
DATE	DATE					
BY	BY					
CHK	CHK					
APP	APP					
REV	REV					
DATE	DATE					
BY	BY					
CHK	CHK					
APP	APP					
REV	REV					
DATE	DATE					
BY	BY					
CHK	CHK					
APP	APP					
REV	REV					
DATE	DATE					
BY	BY					
CHK	CHK					
APP	APP					
REV	REV					
DATE	DATE					
BY	BY					
CHK	CHK					
APP	APP					
REV	REV					
DATE	DATE					
BY	BY					
CHK	CHK					
APP	APP					
REV	REV					
DATE	DATE					
BY	BY					
CHK	CHK					
APP	APP					
REV	REV					
DATE	DATE					
BY	BY					
CHK	CHK					
APP	APP					
REV	REV					
DATE	DATE					
BY	BY					
CHK	CHK					
APP	APP					
REV	REV					
DATE	DATE					
BY	BY					
CHK	CHK					
APP	APP					
REV	REV					
DATE	DATE					
BY	BY					
CHK	CHK					
APP	APP					
REV	REV					
DATE	DATE					
BY	BY					
CHK	CHK					
APP	APP					
REV	REV					
DATE	DATE					
BY	BY					
CHK	CHK					
APP	APP					
REV	REV					
DATE	DATE					
BY	BY					
CHK	CHK					
APP	APP					