

DRAWING MADE IN THIRD ANGLE PROJECTION
 THIS DRAWING IS UNPUBLISHED. RELEASED FOR PUBLICATION
 © COPYRIGHT 19 BY AMP INCORPORATED. ALL INTERNATIONAL RIGHTS RESERVED.

REV. NO.		DATE		DESCRIPTION		DATE	APP.
B	EC	0010-1488-95				4/1/96	CR
E	REV PER EC	0018-0367-00				10/24/98	CR

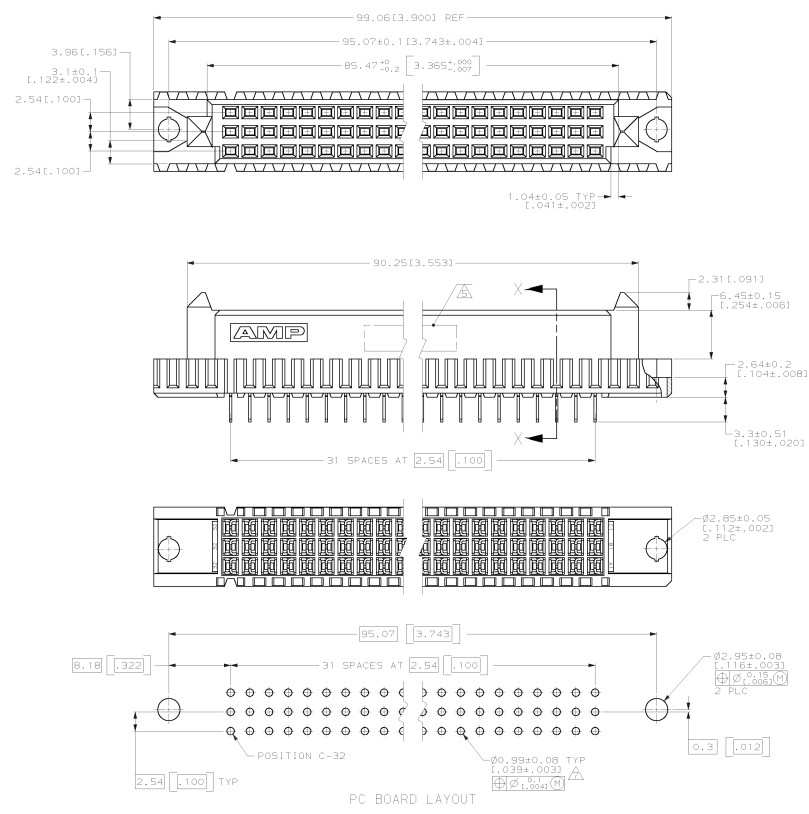

- DIMENSIONS IN BRACKETS ARE IN INCHES.
- HOUSING MATERIAL: GLASS-FILLED POLYESTER, COLOR: GRAY.
- CONTACT MATERIAL: PHOSPHOR BRONZE.
- CONTACT FINISH: 0.00076 [0.00030] GOLD IN CONTACT AREA, 0.00127 [0.00050] NICKEL UNDERPLATE ALL OVER, TIN-LEAD PLATE ON POSTS.
- PART NUMBER, DATE CODE IDENTIFICATION, CSA LOGO THIS APPROXIMATE AREA.
- POINT OF MEASUREMENT FOR GOLD.
- RECOMMENDED HOLE SIZE FOR MANUAL APPLICATION OF CONNECTOR ONTO PC BOARD.
- CONTACT FINISH: DIN 41612 CLASS 2 IN CONTACT AREA, TIN-LEAD PLATE ON POSTS.

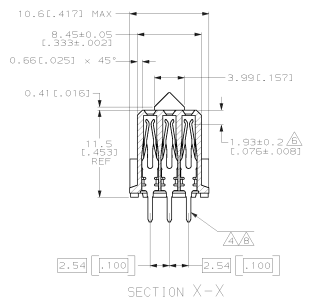

650998-5	△
SUPERSEDED BY 650998-5	△
650998-4	△
PART NUMBER	

DO NOT SCALE PRINT. UNLESS SPECIFIED DIMENSIONS IN IN (INCHES) PREFERENCES ON + P.L.C. SEE # 5.131.0051 UNLESS #	DE L. BRINER 7/16/91	AMP INCORPORATED Harrisburg, PA 17105
	CHK D.C. RUBENDALL 9/10/91	
	APPR D.C. RUBENDALL 9/10/91	NAME
	APPR E.R. FARMER 9/12/91	DATE
MATERIAL HSG △ CONTACT △	PRODUCT SPEC -	RECEPTACLE ASSEMBLY, EUROCARD, TYPE "C" WITH GUIDE FEATURES
FINISH	APPLICATION SPEC -	SIZE D 00779 DRAWING NO 650998
CONT △△	ATTENT -	SCALE 1:1 SHEET 1 OF 1

CUSTOMER DRAWING