

THIS DRAWING IS UNCLASSIFIED
 UNLESS INDICATED OTHERWISE
 © SPANISH ELECTRONICS CORPORATION ALL RIGHTS RESERVED

REV	DATE	DESCRIPTION	BY	CHK	APP
AD 25					
G		REVISED PER EC 0513-0381-05			

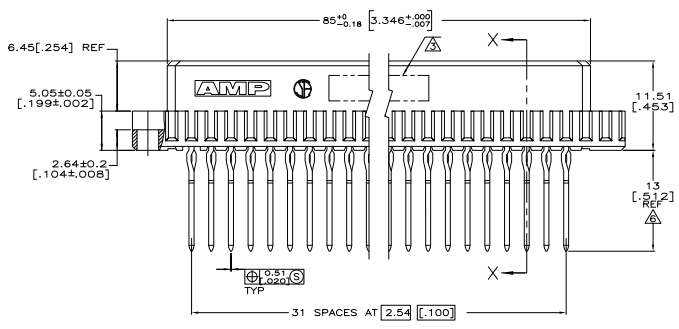

- △ HOUSING MATERIAL: GLASS-FILLED POLYESTER. COLOR: GRAY.
- △ CONTACT MATERIAL: PHOSPHOR BRONZE.
- △ PART NUMBER AND DATE CODE HOT STAMPED IN THIS APPROXIMATE AREA.
- △ ACTION PIN POSTS REQUIRE 1.57[.062] MINIMUM THICK PC BOARD. RECOMMENDED PC BOARD DRILLED HOLES ARE 1.15±0.025[.0453±.0010] DIAMETER WITH 0.02-0.08[.001-.003] COPPER AND 0.008[.0003] MINIMUM TIN-LEAD PLATING. FINISHED HOLE AFTER PLATING IS 1.02±0.08[.040±.002] DIAMETER.
- △ CONTACT FINISH: DIN 41612 CLASS 2 IN CONTACT AREA. TIN-LEAD PLATE ON POSTS.
- △ TAIL LENGTH AFTER SEATING IN PC BOARD.
- △ CONTACT POINT AFTER SEATED IN PC BOARD.
- △ HOT STAMPING ON THIS SIDE.
- △ CONTACT FINISH: DIN 41612 CLASS 2 IN CONTACT AREA AND LAST 5.08[.200] OF POST.
- △ CONTACT FINISH: 0.00076[.000030] GOLD IN CONTACT AREA AND LAST 5.08[.200] OF POST. 0.00127[.000050] NICKEL UNDERPLATE ALL OVER.

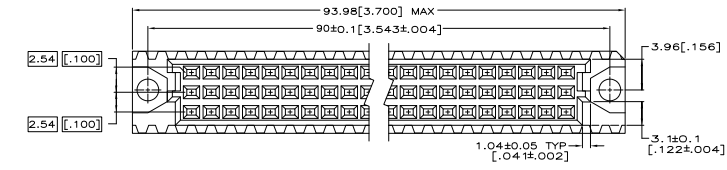
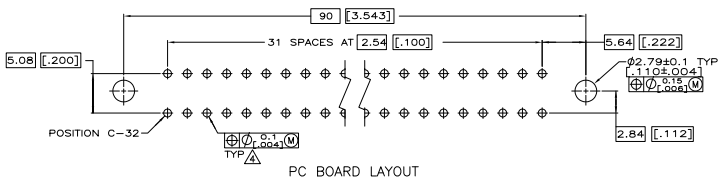
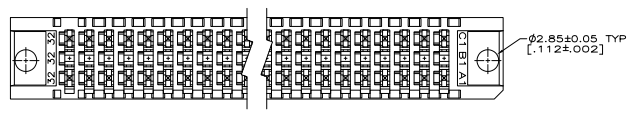
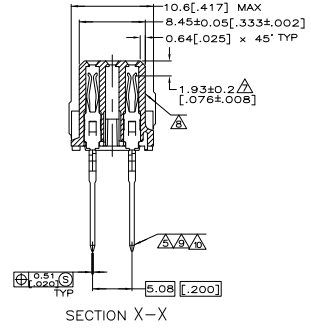

REV	DATE	DESCRIPTION	BY	CHK	APP
1					
2					
3					
4					
5					
6					
7					
8					
9					
10					
11					
12					
13					
14					
15					
16					
17					
18					
19					
20					
21					
22					
23					
24					
25					

REV	DATE	DESCRIPTION	BY	CHK	APP
1					
2					
3					
4					
5					
6					
7					
8					
9					
10					
11					
12					
13					
14					
15					
16					
17					
18					
19					
20					
21					
22					
23					
24					
25					

WIP 440 REV 2/2000