

PCB Accessories

96-Pin DIN Connectors

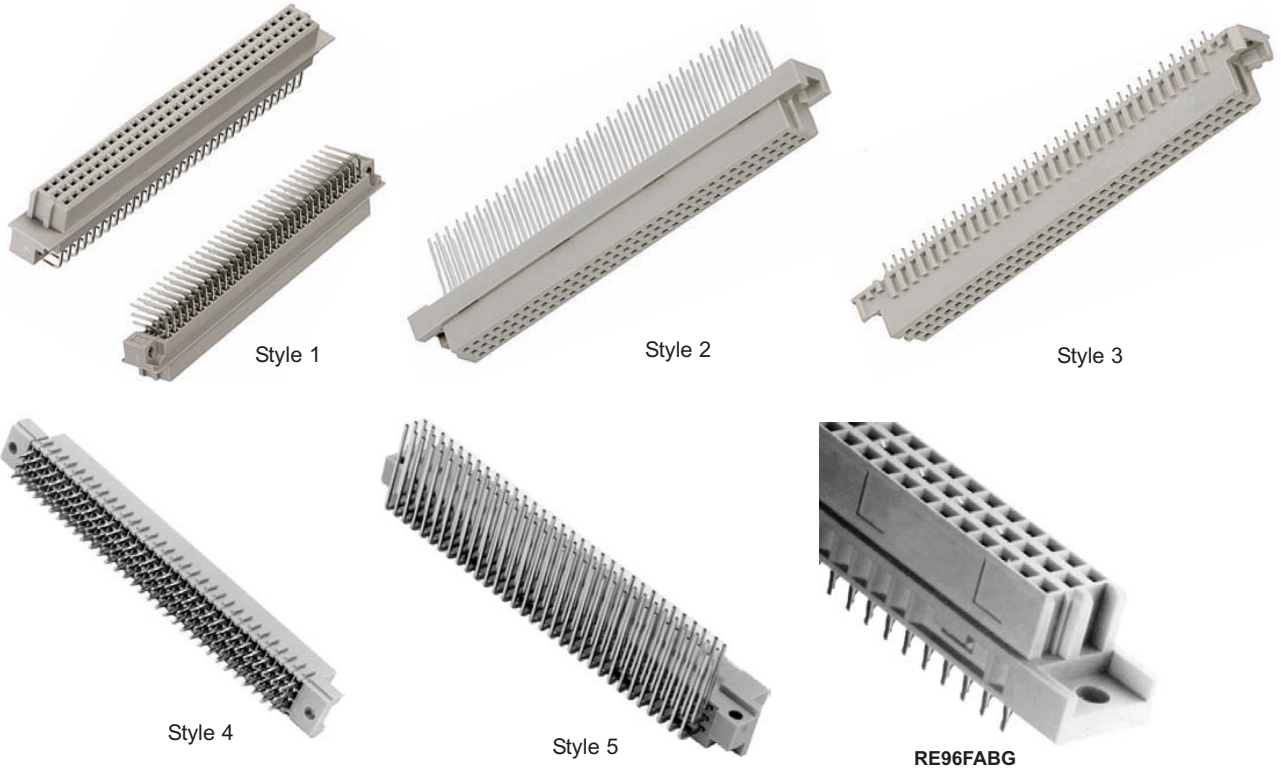

96-Pin DIN Connectors Specifications: Class 2 (DIN 41612)

Insulating Material: Glass-Filled Polycarbonate or polyester sulphone

Contact Material: Copper Alloy
Contact Plating:* .000010" gold over .000050" nickel
Contact Tail: Ni/Gold .000010"
Current Rating: 2.5A at 20°C;
 1A at 70°C

Operating Voltage: 300V AC
Test Voltage: 1000V AC
Contact Resistance: 30 m Ohms max. @ 100mA DC
Insulator Resistance: 1000M Ohms min. @ 500 VDC
Temperature Range: -55°C to + 125°C
Insertion Force: <90 < 20 Lbs.
Insertion Cycles: 400

* Other gold plating specs available;
 64-pin connectors (A & C rows) available upon request.



79900003

Shroud for press-fit wire wrap connectors

www.vectorelect.com

For automatic daisy chaining of VME and VXI backplanes. Eliminates the need for manual jumpering. Pin entry acts like a switch which is activated and closed during insertion. No other moving parts required. Same MTBF as other types. Requires special EPT installation tooling.

Standard VME Bus Signals J1 Switched Pins

| | |
|---------------------------|----------------|
| IACK IN - IACK OUT | a 21-22 |
| BG 0 IN - BG 0 OUT | b 4-5 |
| BG1 IN - BG 0 OUT | b 6-7 |
| BG 2 IN - BG 2 OUT | b 8-9 |
| BG 3 IN BG 3 OUT | b 10-11 |

Ordering Information

| Part No. | Style # | M/F | Contact Length | Type |
|-------------|---------|-----|----------------|---|
| RE96FSR | 1 | F | 0.087" | Solder Tail, Right Angle |
| RE96MSD | 3 | M | 0.157" | Solder Tail |
| RE96MSR-062 | 1 | M | 0.087" | Solder Tail, Right Angle |
| RE96MSR-125 | 1 | M | 0.174" | Solder Tail, Right Angle |
| RE96FW | 2 | F | 0.54" | Wire-Wrap |
| RE96FWR | 1 | F | 0.2" | Wire-Wrap, Right Angle |
| RE96MW | 2 | M | 0.54" | Wire-Wrap |
| RE96FABG | n/a | F | | Auto Bus Grant |
| RE96FSD | 3 | F | 0.157" | Solder Tail |
| RE96FSP | 4 | F | 0.208" | Pressfit Solder Tail |
| RE96FWP | 4 | F | 0.366" | Pressfit Wire-Wrap |
| RE96MWR | 5 | M | 0.505" | Wire-Wrap, Right Angle |
| 79900003 | N/A | F | N/A | Shroud for press-fit wire wrap connectors |



Style 1

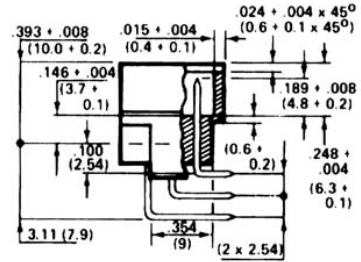
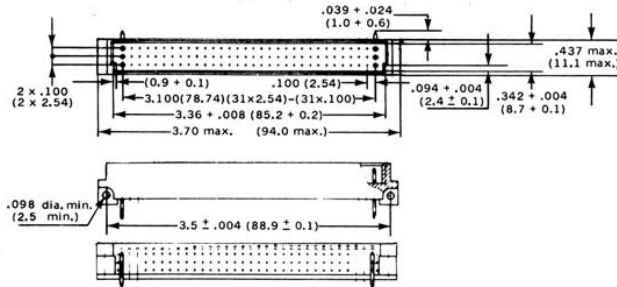

Style 2 & 3

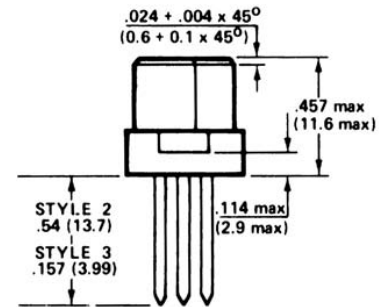
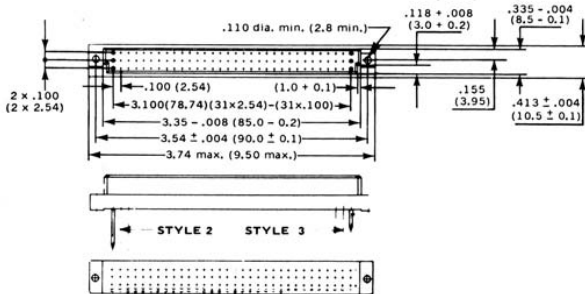

Style 4

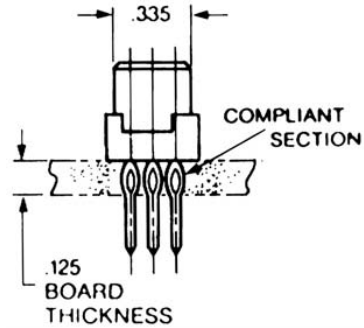
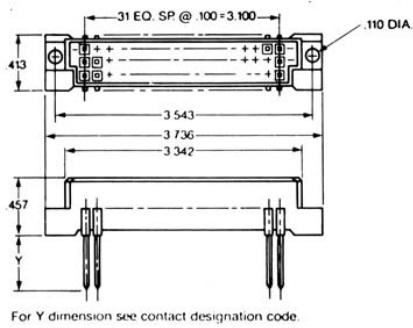

Style 5

