

LOC	DIST	REVISIONS					
AD	25	P	LTR	DESCRIPTION	DATE	DWN	APVD
		0		DRAWN	-	-	-

1. WIRE BARREL WILL ACCEPT 16-18 AWG WIRE.
2. MATES WITH PART NUMBER 148407-1.
3. RECOMMENDED CRIMPING TOOL: DANIELS TOOL #FT8, POSITIONER P/N TP731, SETTING #7 (16 AWG), #6 (18 AWG), STRIP LG 8.13 [.320].

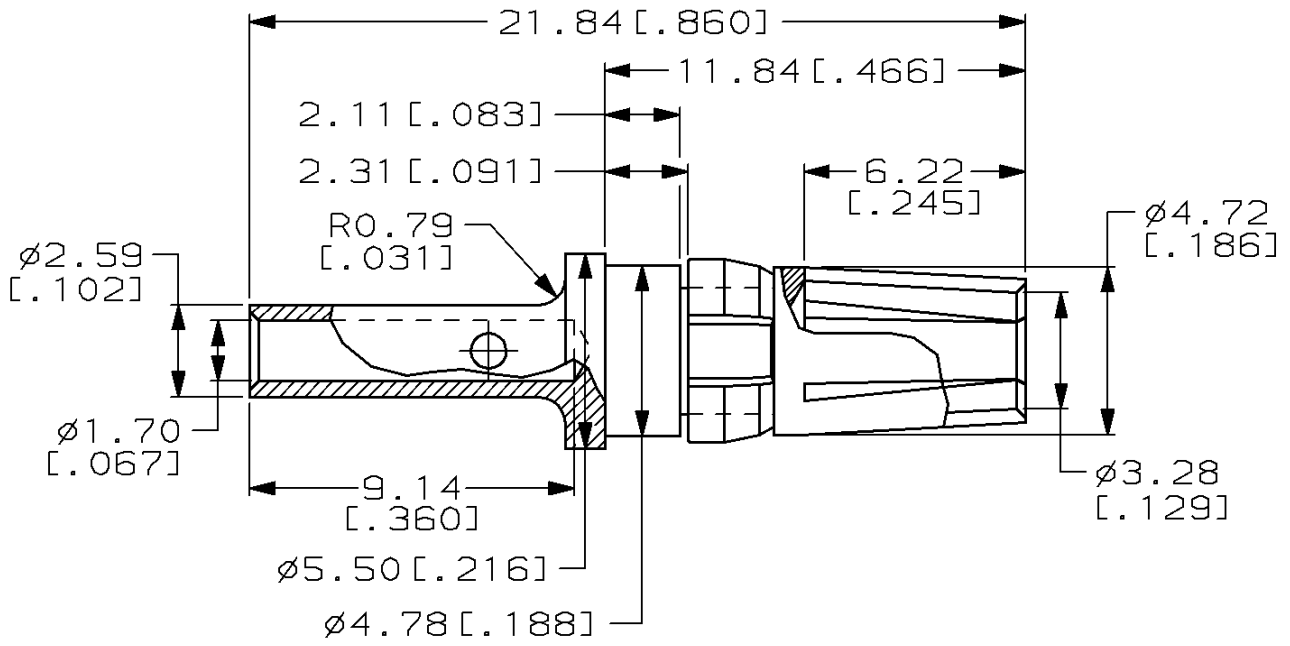

THIS DRAWING IS UNPUBLISHED. BY AMP INCORPORATED. ALL RIGHTS RESERVED. 19

0.00076 [.000030] GOLD	CONTACT; BERYLLIUM COPPER RETAINING RING; BERYLLIUM COPPER	148410-1
CONT AREA FINISH	MATERIAL	PART NUMBER

DIMENSIONS: mm	DWN 10/14/97 L. BRINER	MATERIAL -	FINISH -
	CHK 10/14/97 R. PATTERSON	<b>AMP</b> AMP Incorporated Harrisburg, PA 17105-3608	
TOLERANCES UNLESS OTHERWISE SPECIFIED:	APVD 10/14/97 R. PATTERSON		
0 PLC ±-	PRODUCT SPEC -	SIZE A4	CAGE CODE 00779
1 PLC ±-	APPLICATION SPEC -	DRAWING NO C=148410	RESTRICTED TO -
2 PLC ±0.13 [.005]	WEIGHT -	CUSTOMER DRAWING	
3 PLC ±-		SCALE 5:1	SHEET 1 OF 1
4 PLC ±-			REV 0
ANGLES ±-			