

LOC	DIST	REVISIONS					
AD	25	P	LTR	DESCRIPTION	DATE	DWN	APVD
			0	DRAWN	-	-	-

1. WIRE BARREL WILL ACCEPT 16-18 AWG WIRE.
2. MATES WITH PART NUMBER 148416-1.
3. RECOMMENDED CRIMPING TOOL: DANIELS TOOL #FT8, POSITIONER PART NUMBER TP1211, SETTING #7 (16 AWG), SETTING #6 (18 AWG), STRIP LENGTH 8.13 [.320].

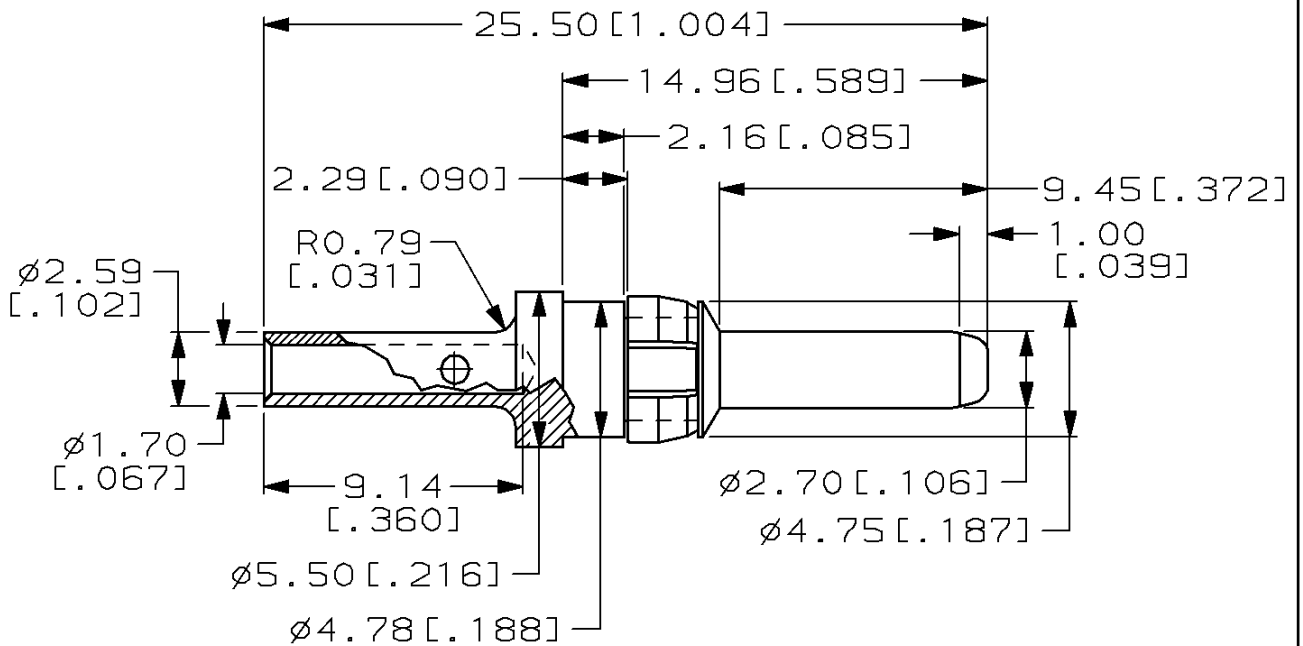

RELEASED FOR PUBLICATION
 ALL RIGHTS RESERVED.
 BY AMP INCORPORATED.
 COPYRIGHT 19

0.00076 [.000030]	CONTACT; BRASS	148409-1
GOLD	RETAINING RING; BERYLLIUM COPPER	
CONT AREA FINISH	MATERIAL	PART NUMBER

DIMENSIONS:	DWN	10/14/97	MATERIAL	FINISH
mm	L. BRINER		-	-
TOLERANCES UNLESS OTHERWISE SPECIFIED:	CHK	10/14/97	AMP AMP Incorporated Harrisburg, PA 17105-3608	
0 PLC ±-	R. PATTERSON			
1 PLC ±-	APVD	10/14/97	NAME PIN CONTACT, POWER, EUROCARD TYPE M, 10 AMP	
2 PLC ±-	R. PATTERSON			
3 PLC ±-	PRODUCT SPEC	-	SIZE	CAGE CODE
4 PLC ±-	APPLICATION SPEC	-	A4	00779
ANGLES ±-	WEIGHT	-	DRAWING NO	RESTRICTED TO
			C=148409	-
	CUSTOMER DRAWING		SCALE	SHEET
			4:1	1 OF 1
				REV
				0