

LOC	DIST	REVISIONS					
AD	25	P	LTR	DESCRIPTION	DATE	DWN	APVD
			0	DRAWN	-	-	-
			A	EC 0504-0015-97	1/21/97	LSB	RAP
			B	EC 0504-0042-97	2/19/97	LSB	RAP

1. WIRE BARREL WILL ACCEPT 12-14 AWG WIRE.
2. MATES WITH PART NUMBER 148249-1.
3. RECOMMENDED CRIMPING TOOL: DANIELS TOOL #M300-BT, POSITIONER PART NUMBER SP689, SETTING #1, STRIP LENGTH 8.13 [.320].

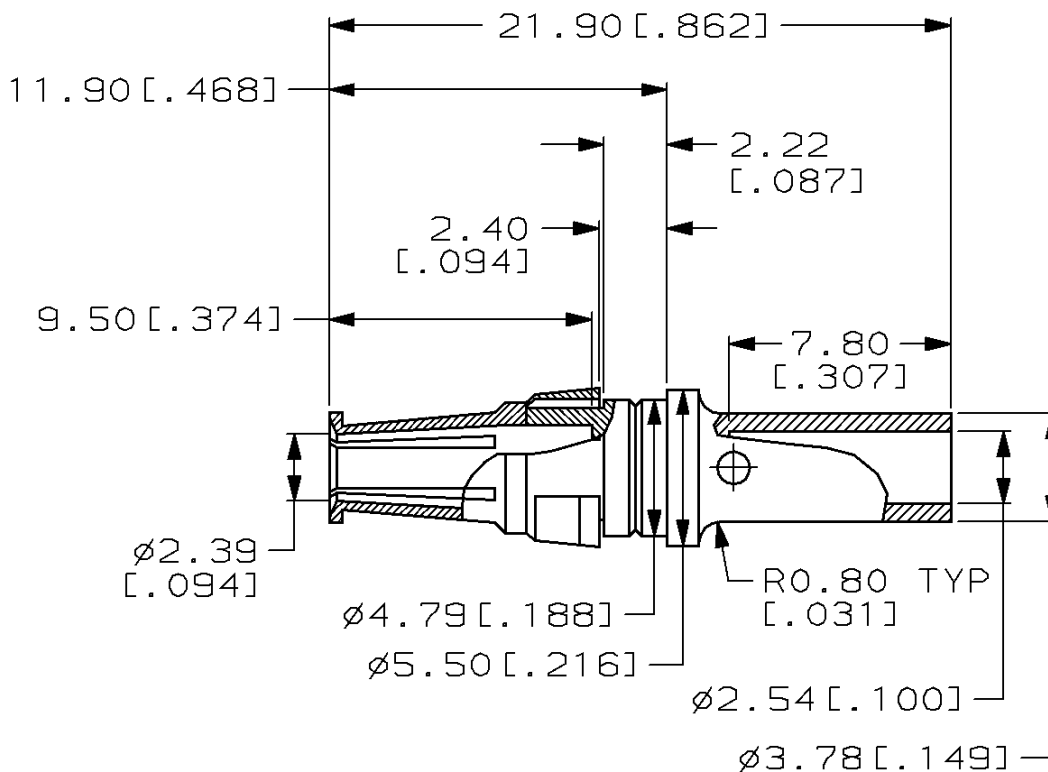

THIS DRAWING IS UNPUBLISHED. BY AMP INCORPORATED. ALL RIGHTS RESERVED. COPYRIGHT 19

0.00076 [.000030] GOLD	CONTACT; BERYLLIUM COPPER	148250-1
FINISH	RETAINING RING; BERYLLIUM COPPER	
	MATERIAL	PART NUMBER

DIMENSIONS:	DWN	4/19/96	MATERIAL	FINISH
mm	L. BRINER		-	-
TOLERANCES UNLESS OTHERWISE SPECIFIED:	CHK	4/19/96	AMP AMP Incorporated Harrisburg, PA 17105-3608	
0 PLC ±-	R. PATTERSON			
1 PLC ±-	APVD	4/19/96	NAME POWER CONTACT, FEMALE F.M.L.B., CRIMP, AWG 12-14, (20 AMP)	
2 PLC ±0.13 [.005]	R. PATTERSON			
3 PLC ±-	PRODUCT SPEC	-	SIZE	CAGE CODE
4 PLC ±-	APPLICATION SPEC	-	A4	00779
ANGLES ±-	WEIGHT	-	DRAWING NO	C=148250
			SCALE	SHEET
			4:1	1 OF 1
			CUSTOMER DRAWING	REV B