

This drawing involves proprietary design rights of Tyco Electronics Corporation, and all design, manufacture, reproduction, use and sale rights regarding the same are expressly reserved. It is submitted for a specific purpose and the recipient by accepting this drawing, assumes custody and control and agrees to take reasonable precautions: (a) that this drawing will not be copied and reproduced in whole or in part, or its contents revealed in any manner, or in any person except to meet the purpose for which it was delivered and (b) that any special features peculiar to this design will not be incorporated in other projects without the expressed written permission of Tyco Electronics Corporation.

REVISIONS			
EC	REV	DESCRIPTION	DATE
CPR	A	NEW RELEASE	3/27/06

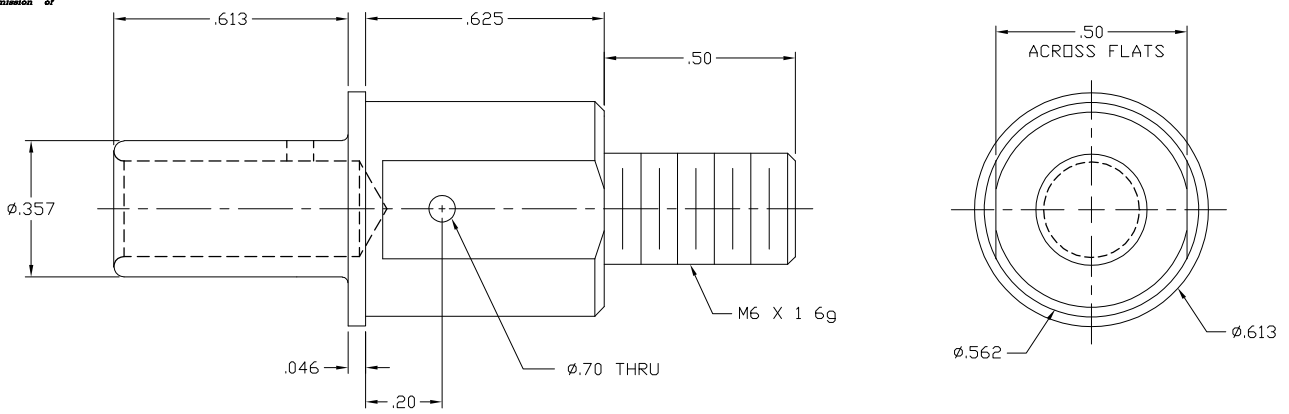

3. FINISHES:
 PIN CONTACT: SILVER PLATE, .000200 MIN THICK
 OVER NICKEL, .000040 MIN THICK

2. MATERIAL:
 PIN CONTACT: COPPER ALLOY.

1. PART NUMBER CHANGES AND OR DESIGN CHANGES AFFECTING ITEM INTERCHANGEABILITY REQUIRE PRIOR TYCO APPROVAL AND AUTHORIZATION BY REVISION TO THIS DRAWING.

NOTES: UNLESS OTHERWISE SPECIFIED

TYCD PART NUMBER
 1766276-1

INCH OR INCH (MM) THIRD ANGLE PROJECTION UNLESS OTHERWISE SPECIFIED DIMENSIONS ARE IN INCHES (METRIC) TOLERANCES ANGLES ± .5° DECIMALS .XXX ± .010 (.25) .XX ± .02 (.3)	DRAWN R. F. A. CHECKED APPROVED S. FLICKINGER DCA APPROVED ACAD FILE NUMBER C1766276A.DWG	DATE 3/27/06	tyco Electronics Tyco Electronics Corporation Menlo Park, Ca 94025 ELCON	TITLE CONTACT, PIN, SIZE #0 M6 X 1 EXT THD, DOUBLE CROWN DRAWERS	SIZE B	DWG NUMBER C= 1766276	REV. A
			DWG SCALE 4=1 SH 1 OF 1				