

4

3

2

1

THIS DRAWING IS UNPUBLISHED. RELEASED FOR PUBLICATION  
 © COPYRIGHT - BY TYCO ELECTRONICS CORPORATION. ALL RIGHTS RESERVED.

LOC	DIST	REVISIONS			
P	LTR	DESCRIPTION	DATE	DWN	APVD
GP	00	A	RELEASED	18OCT06	RG SF

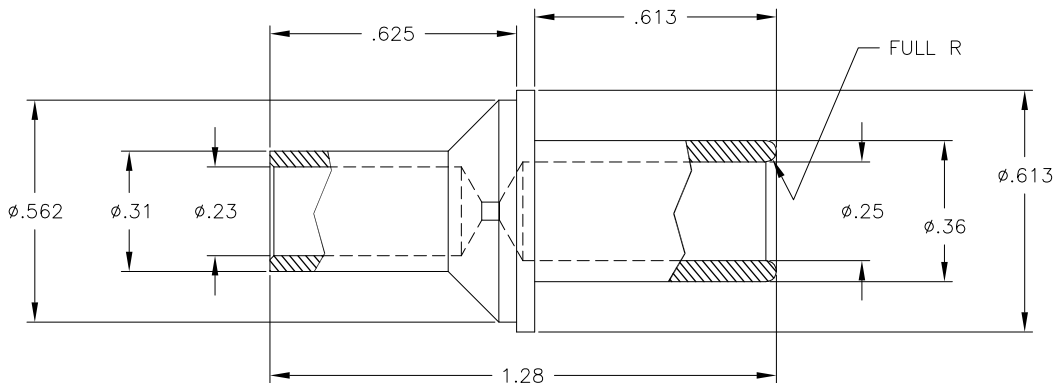

- PART NUMBER CHANGES AND OR DESIGN CHANGES AFFECTING ITEM INTERCHANGEABILITY REQUIRES PRIOR TYCO APPROVAL AND AUTHORIZATION BY REVISION TO THIS DRAWING.
- ITEMS PROVIDED TO THIS SPECIFICATION SHALL BE IDENTIFIED ON THE SHIPPING PACKAGE AS FOLLOWS: PART NUMBER AND DATE CODE.

3 MATERIAL:  
COPPER ALLOY

4 FINISH:  
SILVER PLATED 0.0002" MIN THK. OVER NICKEL .000040" MIN THK.

- THIS No.0 PIN MATES W/ PROBE PROOF No.0 SOCKET.

AS SHOWN	1766190-1
DESCRIPTION	PART NUMBER

THIS DRAWING IS A CONTROLLED DOCUMENT.		DWN	18OCT06	 Tyco Electronics Corporation Harrisburg, PA 17105-3608			
DIMENSIONS:		CHK	18OCT06				
INCHES		APVD	18OCT06				
TOLERANCES UNLESS OTHERWISE SPECIFIED: 0 PLC ± - 1 PLC ± - 2 PLC ± .02 3 PLC ± .010 4 PLC ± - ANGLES ± -		NAME		PIN CONTACT, SIZE No.0 W/ No.6 CRIMP BARREL DOUBLE CROWN			
MATERIAL		PRODUCT SPEC					
FINISH		APPLICATION SPEC		RESTRICTED TO			
-		WEIGHT	-	SIZE	CAGE CODE	DRAWING NO	RESTRICTED TO
- 3		CUSTOMER DRAWING		A3	00779	C=1766190	-
-		SCALE		4:1	SHEET		1 OF 1
-		REV		A			

AMP 1470-19 REV 31MAR2000