

4

3

2

1

THIS DRAWING IS UNPUBLISHED. RELEASED FOR PUBLICATION
 © COPYRIGHT - BY TYCO ELECTRONICS CORPORATION. ALL INTERNATIONAL RIGHTS RESERVED.

LOC		DIST		REVISIONS			
P	LTR	DESCRIPTION	DATE	DWN	APVD		
B		REV PER ECO-10-020184	10JAN2011	RG	NE		

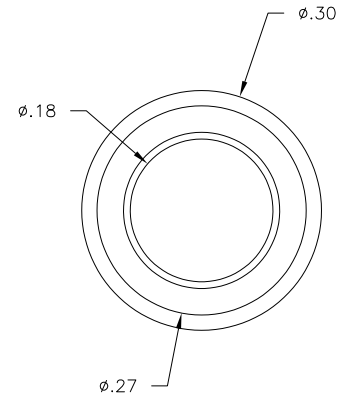
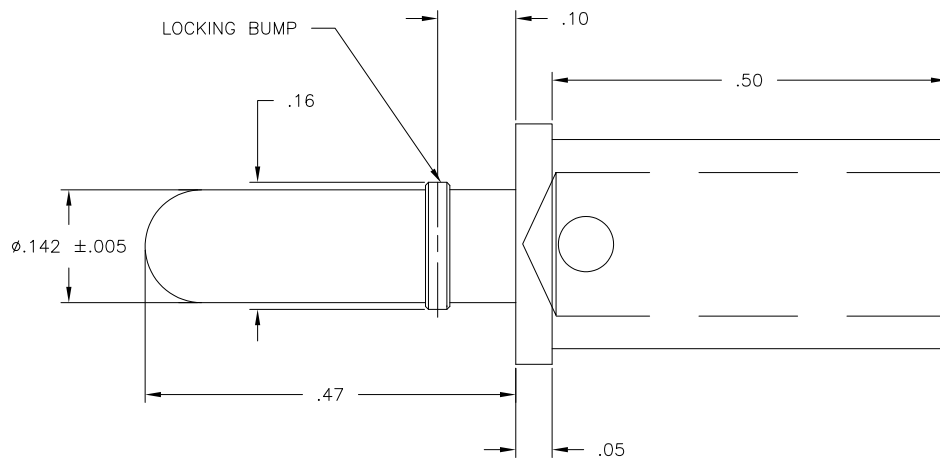

- 4. FINISH: SILVER PLATED
- 3. MATERIAL: TELLURIUM COPPER
- 2. ITEMS PROVIDED TO THIS SPECIFICATION SHALL BE IDENTIFIED ON CONTAINER WITH THE FOLLOWING INFORMATION PART NUMBER AND DATE CODE OF MANUFACTURE.
- 1. PART NUMBER CHANGES AND/OR DESIGN CHANGES AFFECTING ITEM INTERCHANGEABILITY REQUIRE PRIOR TYCO APPROVAL AND AUTHORIZATION BY REVISION TO THIS DRAWING.

1766160-1
PART NUMBER

THIS DRAWING IS A CONTROLLED DOCUMENT.		DWN	10JAN2011	Tyco Electronics Corporation	
		CHK	LOVATO/GRZYBOWSKI	Harrisburg, PA 17105-3608	
		APVD	D,ORRIS	NAME	
		PRODUCT SPEC	D,ORRIS	CONTACT, ICCON LOCKING PIN	
		APPLICATION SPEC		SIZE No.8 WITH	
		WEIGHT		No.8 CRIMP BARREL	
		MATERIAL		SIZE	RESTRICTED TO
		FINISH		A3	
				CAGE CODE	DRAWING NO
				00779	C-1766160
				SCALE	SHEET
				8:1	1 of 1
				CUSTOMER DRAWING	REV
					B