



Features

- Two resistance-matched PTCs in a ceramic housing
- Narrow resistance tolerance
- RoHS compliant*



Model CMF-SD is currently available, although not recommended for new designs. Model **CMF-SDP** is preferred.

BOURNS®

CMF-SD Series - Telecom CPTC Resettable Fuses

Electrical Characteristics

Model	Induction Voltage Withstand	Rated Voltage	Rated Resistance (RN) @ 25 °C		Resistance Matching in Housing	Hold Current	Trip Current	Imax @ 230 VAC	Time to Trip @ Imax / 230 VAC
	VAC		Volts	Ohms					
CMF-SD10	600	220	10	±20 %	±1.0	0.150	0.360	1	<4.5
CMF-SD25	600	230	25	±20 %	±0.5	0.130	0.260	2.8	< 0.3
CMF-SD25-10	600	220	25	±10 %	±0.5	0.130	0.260	2.5	< 0.3
CMF-SD35	600	230	35	±20 %	±0.5	0.100	0.200	3	< 0.2
CMF-SD35-10	600	230	35	±10 %	±0.5	0.100	0.200	3	< 0.2
CMF-SD35A	600	230	35	±20 %	±0.5	0.100	0.200	2.5	< 0.2
CMF-SD35A-10	600	230	35	±10 %	±0.5	0.100	0.200	2.5	< 0.2
CMF-SD50	600	230	50	±20 %	±0.5	0.090	0.190	3	< 0.1
CMF-SD50-10	600	230	50	±10 %	±0.5	0.090	0.190	3	< 0.1
CMF-SD50A	600	230	50	±20 %	±0.5	0.090	0.190	3	< 0.1
CMF-SD50A-10	600	230	50	±10 %	± 0.5	0.090	0.190	3	< 0.1

Test Procedures And Requirements For Model CMF-SD Series

Test	Primary Protection	Test Condition	Requirements
Mains Power Contact - ITU-T K.20, K.21.....	None	230 V rms, 10 ohms, 15 Min.	(Ri-Rf) / Ri < ±10 %
Power Induction - ITU-T K.20, K.21	None	600V rms, 600 ohms, 0.2 seconds, 10 cycles, every 1 Min.	(Ri-Rf) / Ri < ±10 %
Power Induction - ITU-T K.20, K.21	GDT	600 V rms, 600 ohms, 1 second, 10 cycles, every 1 Min.	(Ri-Rf) / Ri < ±10 %
Power Induction - ITU-T K.20, K.21	GDT	600 V rms, 200 ohms, 1 second, 10 cycles, every 1 Min.	(Ri-Rf) / Ri < ±10 %
Lightning Surge - ITU-T K.20, K.21		10/700 μs, 25 ohms, 1.0 kV, 10 Tests, every 1 Min.	(Ri-Rf) / Ri < ±10 %
Lightning Surge		10/1000 μs, 40 ohms, 1.0 kV, 30 Tests, every 3 Min.	(Ri-Rf) / Ri < ±10 %

Ri = R initial
Rf = R final

Typical Part Marking

Represents total content. Layout may vary.

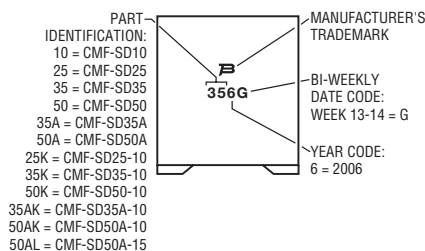

How to Order

CMF - SD 35 A -10 - 2

Product Designator _____
 Style _____
 SD = Surface Mount Dual Pkg.
 Rated Resistance (RN) _____
 10, 25, 35, 50 (25, 35, 50 Ohms)
 Reduced Footprint and Height Option* _____
 Resistance Tolerance Option _____
 Blank = Standard (20 %)
 -10 = 10 %
 Packaging Options _____
 - 2 = Tape & Reel

*Reduced footprint and height option currently unavailable for Model CMF-SD25.

*RoHS Directive 2002/95/EC Jan 27 2003 including Annex.

Specifications are subject to change without notice.

Customers should verify actual device performance in their specific applications.

Applications

Used as a secondary overcurrent protection device in:

- Customer Premise Equipment (CPE)
- Central Office (CO)
- Access equipment

CMF-SD Series - Telecom CPTC Resettable Fuses

BOURNS®

Product Dimensions

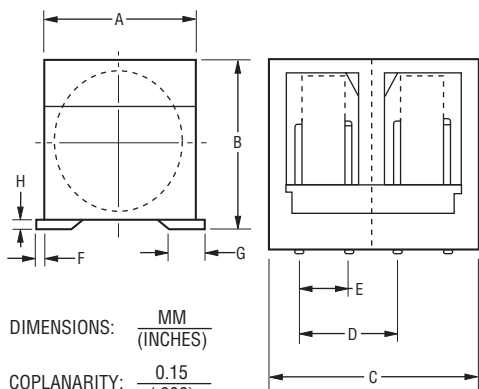

DIMENSIONS: $\frac{\text{MM}}{\text{(INCHES)}}$
 COPLANARITY: $\frac{0.15}{(.006)}$

(Reduced value available on request.)

Packaging Options - Tape and Reel:

CMF-SD10, CMF-SD25, CMF-SD35 & CMF-SD50 = 400 pcs. per reel;
 CMF-SD35A & CMF-SD50A = 500 pcs. per reel

Dim.	CMF-SD10 CMF-SD25 CMF-SD35 CMF-SD50	CMF-SD35A CMF-SD50A
A	$\frac{9.00}{(.354)}$ MAX.	$\frac{7.15}{(.281)}$ MAX.
B	$\frac{10.80}{(.425)}$ MAX.	$\frac{8.50}{(.355)}$ MAX.
C	$\frac{10.20}{(.402)}$ MAX.	$\frac{8.10}{(.319)}$ MAX.
D	$\frac{4.88 - 5.28}{(.192 - .208)}$	$\frac{3.25 - 3.65}{(.128 - .144)}$
E	$\frac{2.41 - 2.61}{(.095 - .103)}$	$\frac{2.41 - 2.61}{(.095 - .103)}$
F	$\frac{0.5}{(.020)}$ MAX.	$\frac{0.5}{(.020)}$ MAX.
G	$\frac{2.5}{(.098)}$	$\frac{2.5}{(.098)}$
H	$\frac{1.0}{(.039)}$	$\frac{1.0}{(.039)}$

Recommended Pad Layout

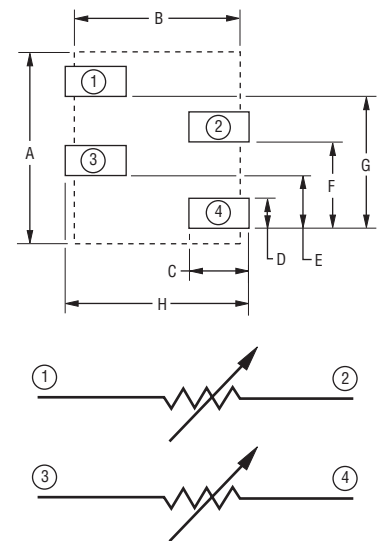

Dim.	CMF-SD10 CMF-SD25 CMF-SD35 CMF-SD50	CMF-SD35A CMF-SD50A
A	$\frac{10.0}{(.394)}$	$\frac{8.00}{(.315)}$
B	$\frac{8.80}{(.346)}$	$\frac{7.05}{(.278)}$
C	$\frac{3.20}{(.126)}$	$\frac{2.75}{(.108)}$
D	$\frac{2.00}{(.079)}$	$\frac{2.00}{(.079)}$
E	$\frac{2.60}{(.102)}$	$\frac{2.51}{(.099)}$
F	$\frac{5.00}{(.197)}$	$\frac{3.45}{(.136)}$
G	$\frac{7.60}{(.299)}$	$\frac{5.95}{(.234)}$
H	$\frac{10.0}{(.394)}$	$\frac{8.15}{(.321)}$

DIMENSIONS: $\frac{\text{MM}}{\text{(INCHES)}}$

Solder Reflow Recommendations

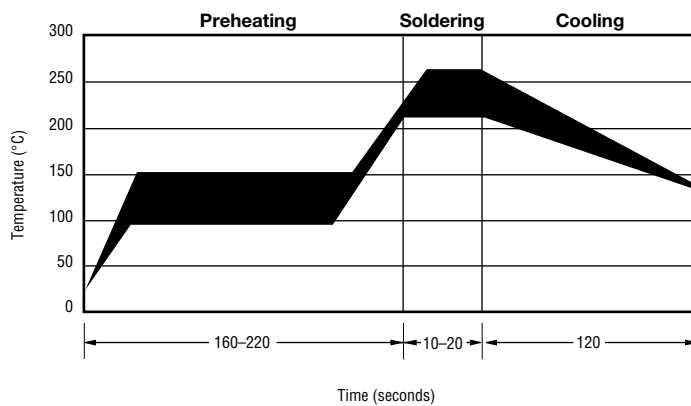

Solder reflow

- Recommended reflow methods: IR, vapor phase oven, hot air oven.
- Devices are not designed to be wave soldered to the bottom side of the board.
- Gluing the devices is not recommended.
- Recommended maximum paste thickness is 0.25 mm (.010 inch).
- Devices can be cleaned using standard industry methods and solvents.

Note:

- If reflow temperatures exceed the recommended profile, devices may not meet the performance requirements.

Rework

- A device should not be reworked.

CMF-SD SERIES, REV. O, 05/10

Specifications are subject to change without notice.
 Customers should verify actual device performance in their specific applications.

CMF-SD Series Tape and Reel Specifications

BOURNS®

Tape Dimensions per EIA 481-2	CMF-SD10 CMF-SD25-2 CMF-SD35-2 CMF-SD50-2	CMF-SD35A-2 CMF-SD50A-2
	W	$\frac{24.0 +0.30/-0.10}{(0.945 +0.012/-0.004)}$
P ₀	$\frac{4.00 \pm 0.10}{(0.157 \pm 0.004)}$	$\frac{4.00 \pm 0.10}{(0.157 \pm 0.004)}$
P	$\frac{16.0 \pm 0.10}{(0.630 \pm 0.004)}$	$\frac{12.0 \pm 0.10}{(0.472 \pm 0.004)}$
P ₂	$\frac{2.00 \pm 0.10}{(0.079 \pm 0.004)}$	$\frac{2.00 \pm 0.10}{(0.079 \pm 0.004)}$
A ₀	$\frac{10.2 \pm 0.10}{(0.402 \pm 0.004)}$	$\frac{7.30 \pm 0.10}{(0.287 \pm 0.004)}$
B ₀	$\frac{9.0 \pm 0.10}{(0.354 \pm 0.004)}$	$\frac{8.30 \pm 0.10}{(0.327 \pm 0.004)}$
D	$\frac{1.5 +0.10/-0.0}{(0.059 + 0.004/-0)}$	$\frac{1.5 \pm 0.10}{(0.059 \pm 0.004)}$
F	$\frac{11.5 \pm 0.10}{(0.453 \pm 0.004)}$	$\frac{11.5 \pm 0.10}{(0.453 \pm 0.004)}$
E	$\frac{1.75 \pm 0.10}{(0.069 \pm 0.004)}$	$\frac{1.75 \pm 0.10}{(0.069 \pm 0.004)}$
T max.	$\frac{0.50}{(0.020)}$	$\frac{0.50 \pm 0.005}{(0.020 \pm 0.002)}$
T ₁ max.	$\frac{0.1}{(0.004)}$	$\frac{0.1}{(0.004)}$
K ₀	$\frac{11.0 \pm 0.10}{(0.433 \pm 0.004)}$	$\frac{8.80 \pm 0.10}{(0.346 \pm 0.004)}$

**CMF-SD25-2
CMF-SD35-2
CMF-SD50-2**

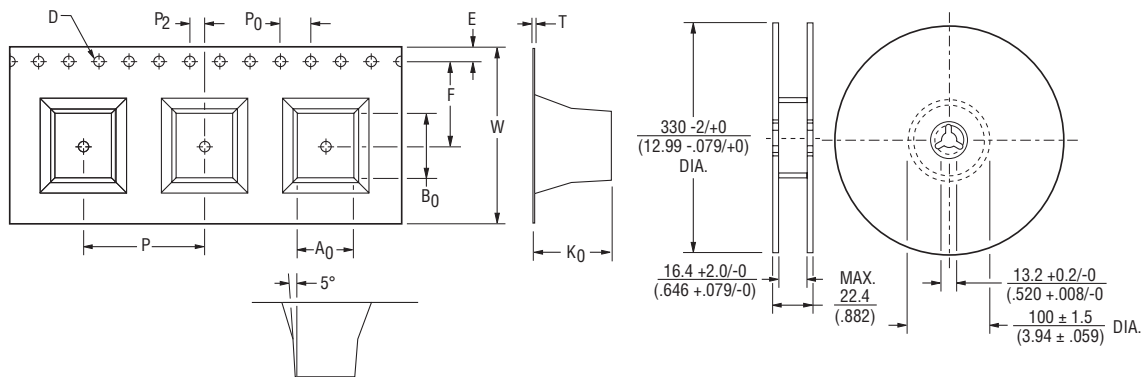

**CMF-SD35A-2
CMF-SD50A-2**

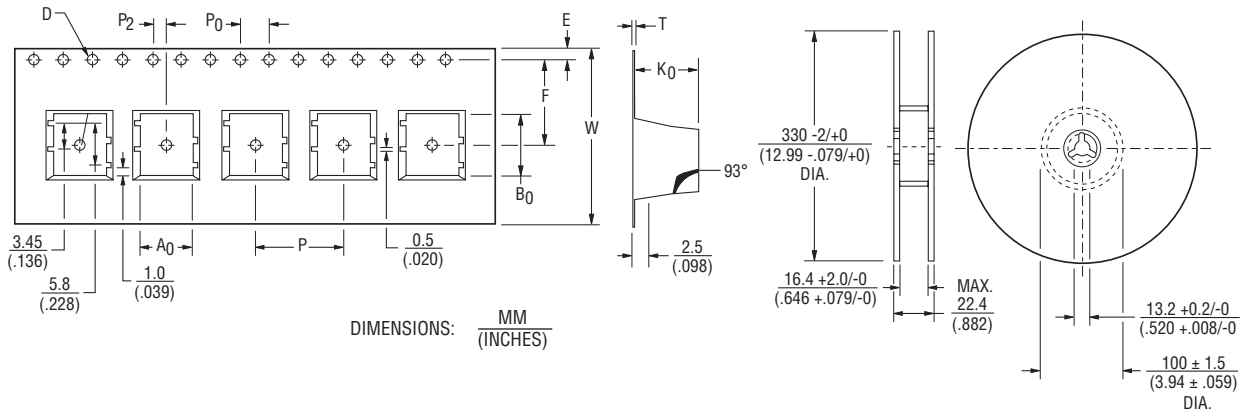

Specifications are subject to change without notice.
Customers should verify actual device performance in their specific applications.