

GSAD0808

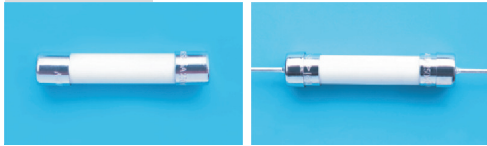

Electrical Characteristics (UL/CSA STD. 248-14)

Testing current	Blow Time	
	Minimum	Maximum
100%	4 Hrs.	N/A
135%	N/A	1 Hr
200%	5 sec	30 sec

Approvals



Safety Agency Approvals	Type	Amp range / Volt @ I.R.ability
<ul style="list-style-type: none"> UL Listed File No. E20624 SP Certified File No. LR39772 	GSA / GSAP	63mA - 8A / 125V AC@ 10,000A 63mA - 1A / 250V AC@ 35A >1A - 3.5A / 250V AC@ 100A >3.5A - 8A / 250V AC@ 200A
<ul style="list-style-type: none"> A Recognized File No. E20624 CSA Acceptance File No. LR39772 	GSA / GSAP	10A - 15A / 125V AC@ 10,000A 10A - 15A / 250V AC@ 750A
<ul style="list-style-type: none"> PS File No. JET1037-31003-1001, JET1037-31003-1003 File No. JET1037-31003-1002 	GSA / GSAP	1A - 5A / 125V AC@ 500A >5A - 15A / 125V AC@ 300A

RoHS 6 Compliant Product

Operating Temperature

-55°C to +125°C

Physical Specification

Materials

Ceramic body / Nickel Plated Brass Caps

Lead wire:

Matte Tin Plated Copper, Diameter 0.032" , 5A and less
Diameter 0.040" , 6A and above

Marking

On fuse:

"bel", "GSA", "Current Rating", "Voltage Rating",
"Appropriate Safety Logos", "✓" (RoHS 6 compliant)

On label:

"bel", "GSA" or "GSAP", "Current Rating", "Voltage Rating",
"Interrupting Rating", "Appropriate Safety Logos" and "✓", "e" (China RoHS compliant)

Voltage on fuse:

250V for 63mA to 15A

Packaging

1. In bulk:

GSA - 1,000 pcs per box; **GSAP** - 500 pcs per box

2. On Axial Tape & Reel:

1,000 pcs per reel

3. Tape & Reel specification:

per EIA-296-E & IEC 286-1

@ 10mm Pitch and 73mm inside Tape Spacing

Catalog Number	Ampere Rating	Typical Cold Resistance (ohm)	Volt-drop @ 100% In (Volt) max.	Melting I ² T < 10 mSec (A ² Sec)	Melting I ² T @ 10 In (A ² Sec)	Maximum Power Dissipation (W)
GSA (P) 63-R	63mA	80.4	6.92	0.087	0.098	0.71
GSA (P) 80-R	80mA	54.0	5.73	0.135	0.152	0.74
GSA (P) 100-R	100mA	22.0	4.00	0.209	0.238	0.55
GSA (P) 125-R	125mA	15.9	2.82	0.323	0.372	0.58
GSA (P) 160-R	160mA	11.5	2.33	0.499	0.581	0.60
GSA (P) 200-R	200mA	8.30	1.93	0.773	0.908	0.63
GSA (P) 250-R	250mA	4.92	1.62	1.20	1.42	0.66
GSA (P) 300-R	300mA	3.31	1.35	1.85	2.22	0.70
GSA (P) 375-R	375mA	2.44	1.18	2.6	3.2	0.73
GSA (P) 500-R	500mA	1.50	0.949	4.4	5.4	0.78
GSA (P) 600-R	600mA	1.01	0.794	6.9	8.5	0.82
GSA (P) 700-R	700mA	0.825	0.727	8.5	11	0.84
GSA (P) 750-R	750mA	0.740	0.691	10	12	0.85
GSA (P) 1-R	1A	0.455	0.557	16	21	0.91
GSA (P) 1.25-R	1.25A	0.306	0.466	25	32	0.96
GSA (P) 1.6-R	1.6A	0.206	0.390	39	50	1.01
GSA (P) 2-R	2A	0.138	0.327	61	79	1.06
GSA (P) 2.5-R	2.5A	0.093	0.274	94	123	1.12
GSA (P) 3-R	3A	0.062	0.229	146	192	1.18
GSA (P) 4-R	4A	0.042	0.192	226	300	1.24
GSA (P) 5-R	5A	0.028	0.161	349	469	1.31
GSA (P) 6-R	6A	0.019	0.163	286	455	1.61
GSA (P) 7-R	7A	0.016	0.157	372	592	1.81
GSA (P) 8-R	8A	0.014	0.150	483	769	1.95
GSA (P) 10-R	10A	0.010	0.139	817	1300	2.26
GSA (P) 12-R	12A	0.0081	0.129	1277	2031	2.56
GSA (P) 15-R	15A	0.0060	0.120	2123	3377	2.96

Consult manufacturer for other ratings

Mechanical Dimensions

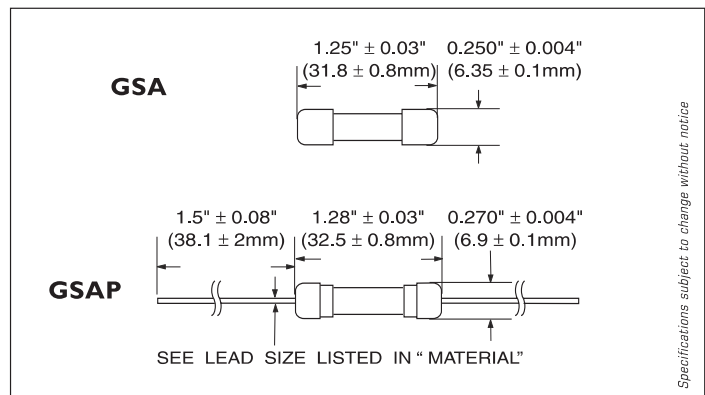

Specifications subject to change without notice

ORDERING INFORMATION SEE LAST 2 PAGES

Type GSA / GSAP
Slow Blow Fuse Series

1/4 x 1 1/4 inch Ceramic Tube
 RoHS 6 Compliant



GSAC0808

GSA / GSAP - TIME CURRENT CHARACTERISTIC CURVE

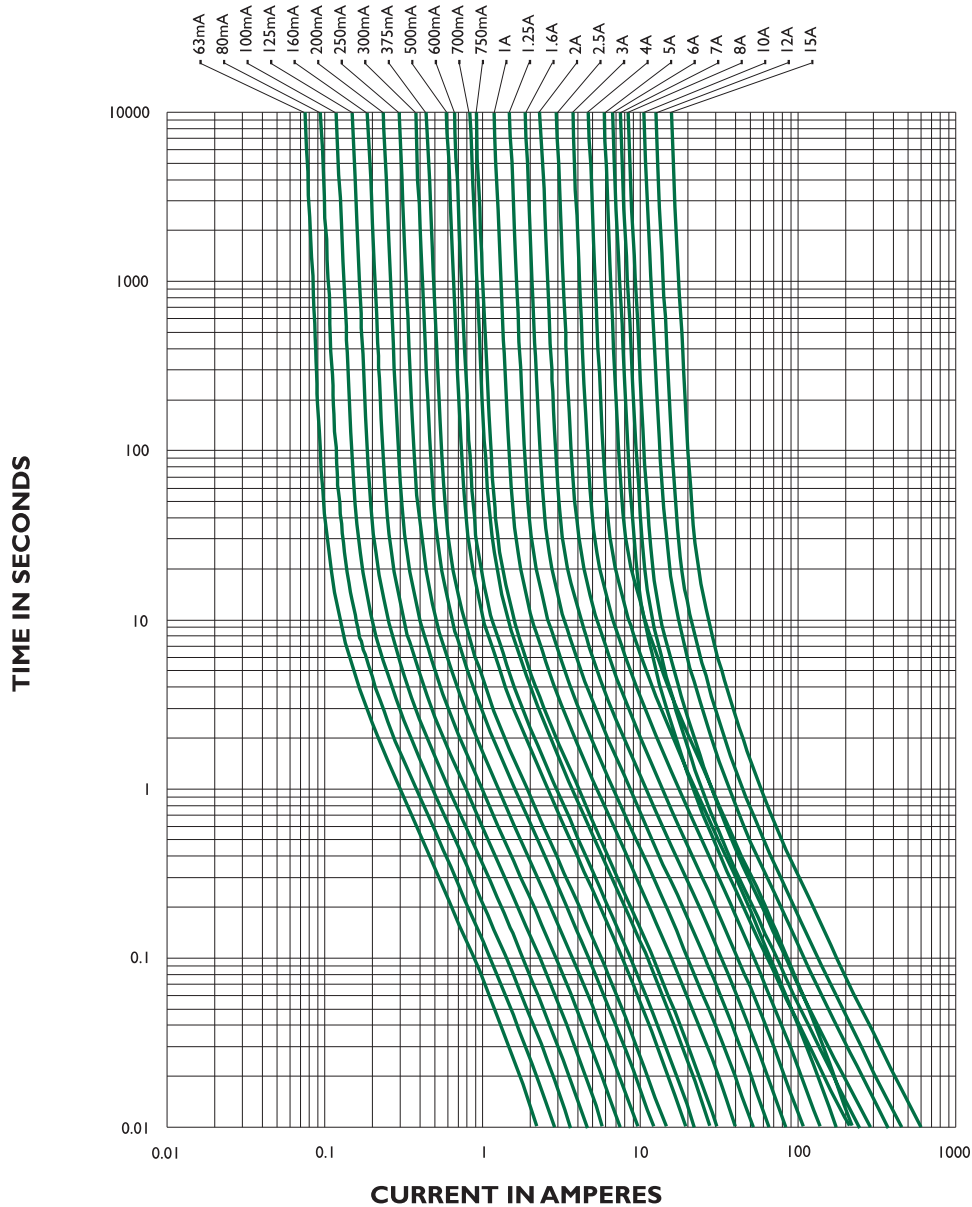

Specifications subject to change without notice

NOTE - see important information under "User Guide" on P.08

Corporate Office

Bel Fuse Inc.
 206 Van Vorst Street, Jersey City, NJ 07302
 Tel: 201-432-0463
 Fax: 201-432-9542
 E-Mail: belfuse@belfuse.com
 Website: www.belfuse.com

Far East Office

Bel Fuse Ltd.
 8F/8 Luk Hop Street
 San Po Kong
 Kowloon, Hong Kong
 Tel: 852-2328-5515
 Fax: 852-2352-3706

European Office

Bel Fuse Europe Ltd.
 Preston Technology Management Centre
 Marsh Lane, Preston PR1 8UQ
 Lancashire, U.K
 Tel: 44-1772-556601
 Fax: 44-1772-888366