



SinglFuse™ SF-0402S Series Features

- Single blow fuse for overcurrent protection
- 1005 (EIA 0402) miniature footprint
- Slow blow fuse
- UL certified
- RoHS compliant* and halogen free**
- Thin film chip fuse
- Surface mount packaging for automated assembly

SF-0402S Series - Slow Blow Surface Mount Fuses

Electrical Characteristics

Model	Rated Current (Amps)	Fusing Time	Resistance (mΩ) Typ.***	Rated Voltage	Breaking Capacity	Typical I ² t (A ² s)
SF-0402S050	0.50	Open within 5 sec. at 250 % rated current	235	DC 24 V	DC24 V 35 A	0.00370
SF-0402S080	0.80		86			0.00947
SF-0402S100	1.00		64			0.01479
SF-0402S125	1.25		45			0.02310
SF-0402S150	1.50		35			0.02400
SF-0402S160	1.60		32			0.03734
SF-0402S200	2.00		24			0.04040
SF-0402S250	2.50		19			0.06760
SF-0402S300	3.00		15			0.09860
SF-0402S315	3.15		14			0.10868
SF-0402S400	4.00		10.5			0.11450

***Resistance value was measured with less than 10 % of rated current.

Reliability Testing

Parameter	Requirement	Test Method
Carrying Capacity.....	No fusing.....	Rated current, 4 hours
Fusing Time.....	Within 5 seconds.....	250 % of its rated current
Interrupting Ability.....	No mechanical damages.....	After the fuse is interrupted, rated voltage applied for 30 seconds again
Bending Test.....	No mechanical damages.....	Distance between holding points: 90 mm, Bending: 3 mm, 1 time, 30 seconds
Resistance to Solder Heat.....	±20 %.....	260 °C ±5 °C, 10 seconds ±1 second
Solderability.....	95 % coverage minimum.....	235 °C ±5 °C, 2 ±0.5 second
Temperature Rise.....	<75 °.....	245 °C ±5 °C, 2 ±0.5 second (lead free)
Resistance to Dry Heat.....	±20 %.....	100 % of its rated current, measure of surface temperature
Resistance to Solvent.....	No evident damage on protective.....	105 °C ±5 °C, 1000 hours
Residual Resistance.....	10k W or more.....	23 °C ±5 °C of isopropyl alcohol, 90 seconds coating and marking
Thermal Shock.....	DR < 10 %.....	Measure DC resistance after fusing
		-20 °C / +25 °C / +125 °C / +25 °C, 10 cycles

Typical Part Marking

Represents total content. Layout may vary.



RATING CURRENT (A)
 F = 0.50 N = 1.60
 * = 0.75 S = 2.00
 K = 0.80 T = 2.50
 L = 1.00 3 = 3.00
 M = 1.25 U = 3.15
 P = 1.50 W = 4.00

How to Order

SF - 0402 S 050 - 2

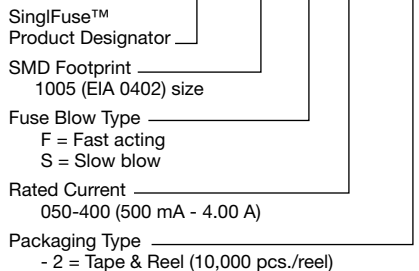

Asia-Pacific:
 Tel: +886-2 2562-4117
 Fax: +886-2 2562-4116

Europe:
 Tel: +41-41 768 5555
 Fax: +41-41 768 5510

The Americas:
 Tel: +1-951 781-5500
 Fax: +1-951 781-5700

www.bourns.com

* RoHS Directive 2002/95/EC Jan 27 2003 including Annex.

** Bourns is using the definition that appears to be the prevalent definition used as the industry standard at this time. The Bourns definition of "halogen-free" is: Bromine (Br) content: ≤ 900 ppm; Chlorine (Cl) content: ≤ 900 ppm; Total Br + Cl content: ≤ 1500 ppm.

"SinglFuse" is a trademark of Bourns, Inc.

Specifications are subject to change without notice.

Customers should verify actual device performance in their specific applications.

SingFuse™ SF-0402S Series Applications

- Portable memory
- LCD monitors
- Disk drives
- PDAs
- Digital cameras
- DVDs
- Cell phones
- Rechargeable battery packs
- Battery chargers
- Set top boxes
- Industrial controllers

SF-0402S Series - Slow Blow Surface Mount Fuses **BOURNS®**

Solder Reflow Recommendations

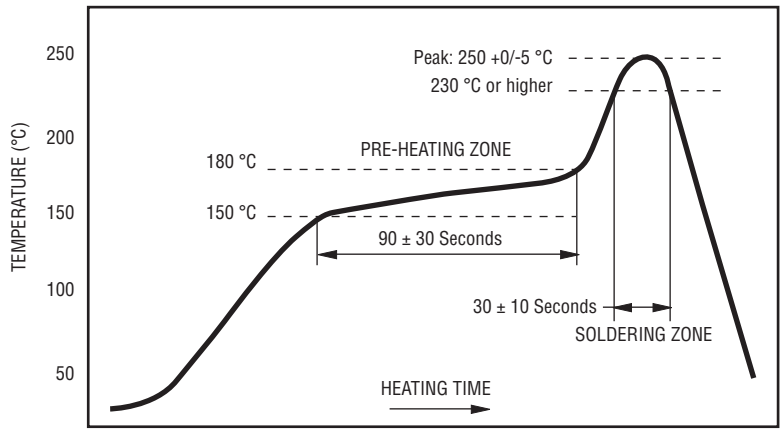

PEAK: 250 +0/-5 °C, 5 seconds
 PRE-HEATING ZONE: 150 to 180 °C, 90 ± 30 seconds
 SOLDERING ZONE: 230 °C or higher, 30 ± 10 seconds

Product Dimensions

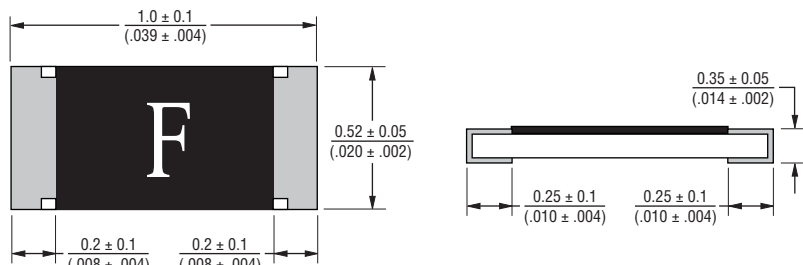

PACKAGING: 10,000 pcs./reel

Recommended Pad Layout

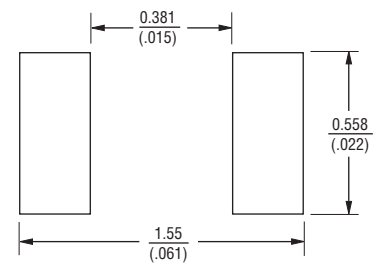

Thermal Derating Curve

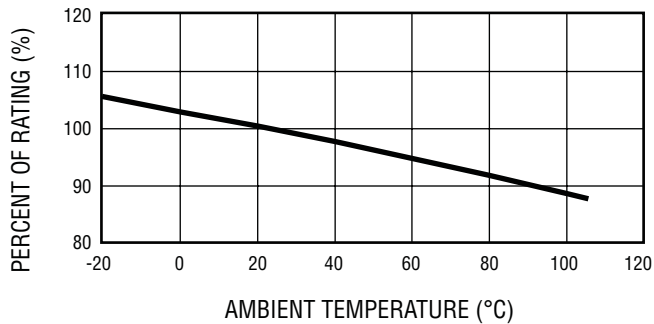

Construction & Material Content

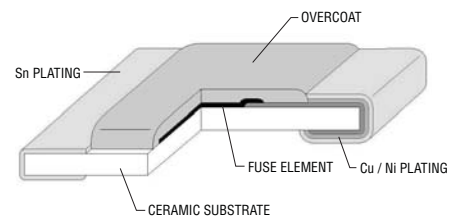

Operating Temperature..... -40 °C to +105 °C

Storage Conditions

 Temperature +5 °C to +35 °C

 Humidity 40 % to 75 %

 Shelf Life..... 2 years from manufacturing date

Specifications are subject to change without notice.
 Customers should verify actual device performance in their specific applications.

SF-0402S Series - Slow Blow Surface Mount Fuses

BOURNS®

Average Time Current Curves

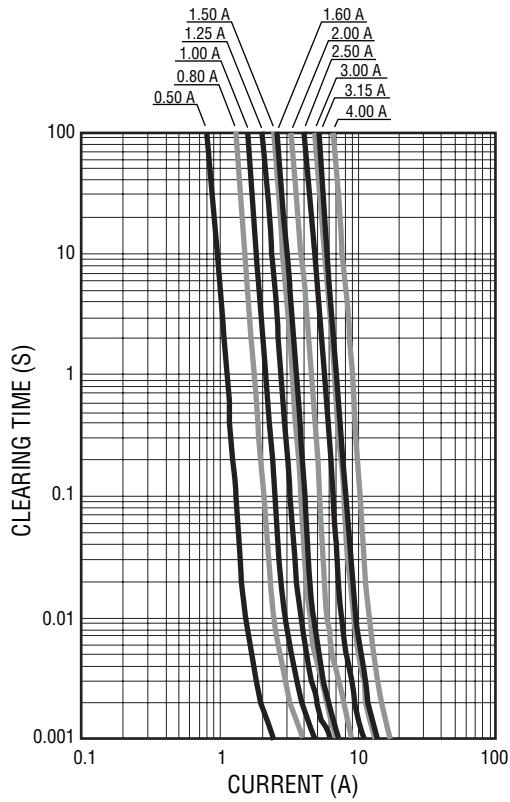

Minimum I²T V Clear Time Curves

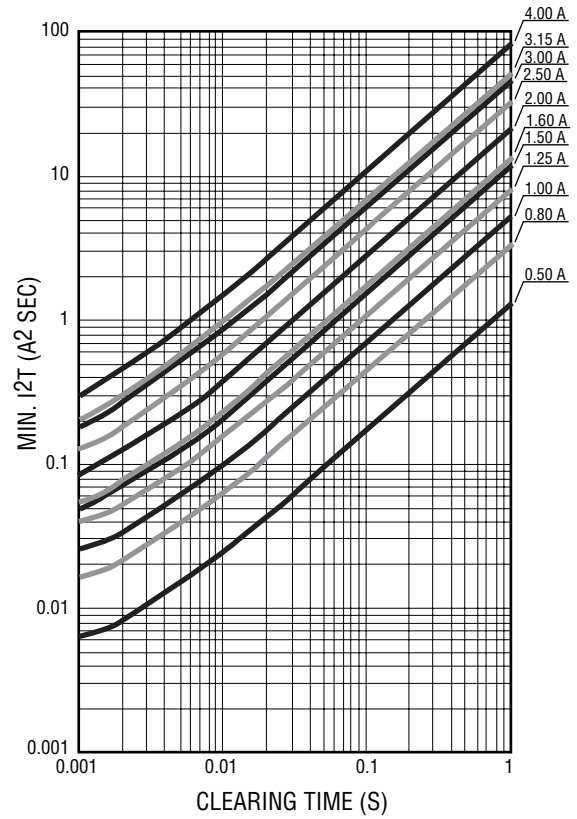

REV. C 12/20/10

Specifications are subject to change without notice.
Customers should verify actual device performance in their specific applications.

SF-0402S Series Tape and Reel Specifications

BOURNS®

Tape Dimensions	SF-0402S Series per EIA 481-2
W	$\frac{8.0 \pm 0.2}{(.315 \pm .008)}$
P ₀	$\frac{4.0 \pm 0.1}{(.157 \pm .004)}$
P ₁	$\frac{2.0 \pm 0.1}{(.079 \pm .004)}$
P ₂	$\frac{2.0 \pm 0.05}{(.079 \pm .002)}$
A	$\frac{0.7 \pm 0.05}{(.028 \pm .002)}$
B	$\frac{1.2 \pm 0.05}{(.047 \pm .002)}$
F	$\frac{3.5 \pm 0.05}{(.138 \pm .002)}$
E	$\frac{1.75 \pm 0.1}{(.069 \pm .004)}$
D ₀	$\frac{1.5 \pm 0.1}{(.059 \pm .004)}$
T	$\frac{0.45 \pm 0.01}{(.018 \pm .004)}$
Reel Dimensions	
A	$\frac{180 \pm 0/-3.0}{(7.087 \pm 0/- .118)}$
B Min.	$\frac{60.0}{(2.362)}$
C	$\frac{13.0 \pm 1.0}{(.512 \pm .039)}$
W	$\frac{9.0 \pm 1.0}{(.354 \pm .039)}$
T	$\frac{11.4 \pm 2.0}{(.449 \pm .079)}$

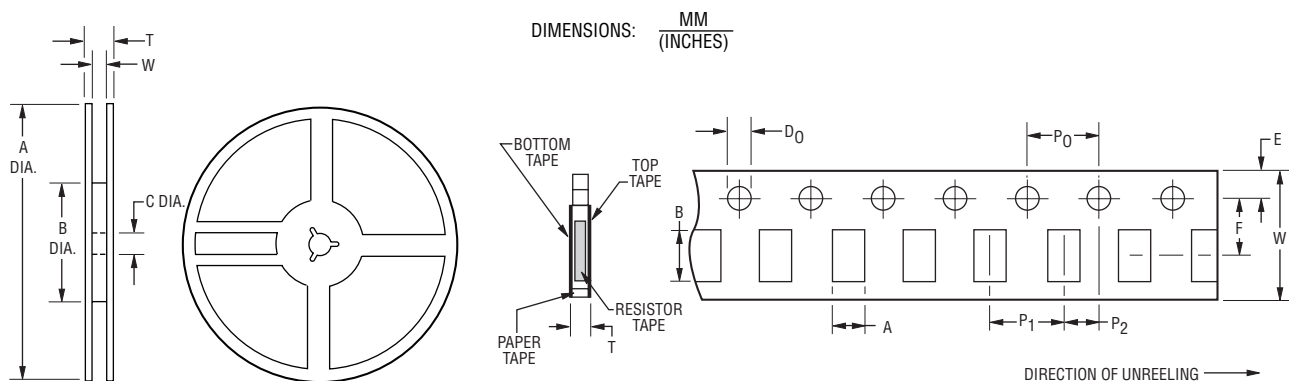

Specifications are subject to change without notice.
Customers should verify actual device performance in their specific applications.