

RoHS **312/318 Series** Lead-Free 3AG, Fast-Acting Fuse



Description

The 3AG Fast-Acting Fuse solves a broad range of application requirements while offering reliable performance and cost-effective circuit protection.

Features

- In accordance with UL Standard 248-14
- Available in cartridge and axial lead format and with various forming dimensions
- RoHS compliant and Lead-free (except 10mA and 31mA rated items)

Applications

Used as supplementary protection in appliance or utilization equipment to provide individual protection for components or internal circuits.

Agency Approvals

Agency	Agency File Number	Ampere Range
	E10480 AU1410	312 Series: 10mA - 10A/ 318 Series: 31mA - 10A 312 Series: 12A - 30A
	LR 29862	312 Series: 10mA - 30A 318 Series: 31mA - 10A
	NBK040205- E10480B/F	312/318 Series: 1A - 10A
	E10480	318 Series: 12A - 30A
	SU05001- 5005/5006/6005/6008	312/318 Series: 1A/ 1.25A / 1.6A/ 2A - 10A
		312 Series: 10mA - 10A 318 Series: 31mA - 10A

Electrical Characteristics for Series

% of Ampere Rating	Ampere Rating	Opening Time
100%	10mA – 35A	4 hours, Minimum
135%	10mA – 35A	1 hour, Maximum
200%	10mA – 10A	5 sec., Maximum
	12A – 30A	10 sec., Maximum
	35A	20 sec., Maximum

Electrical Characteristic Specifications by Item

Amp Code	Ampere Rating (A)	Voltage Rating (V)	Interrupting Rating	Nominal Cold Resistance (Ohms)	Nominal Melting I ² t (A ² sec)	Agency Approvals					
						UL	cULus	K	PS E	SF	CE
.10*	0.01	250	35A@250Vac 10KA@125Vac	177.4000	NA	x				x	x**
.031*	0.031	250		23.6500	0.0000300	x				x	x
.062	0.062	250		24.7000	0.000249	x				x	x
.100	0.1	250		11.2800	0.00102	x				x	x
.125	0.125	250		7.1450	0.00289	x				x	x
.150	0.15	250		5.1300	0.00550	x				x	x
.175	0.175	250		3.8750	0.00960	x				x	x
.187	0.187	250		3.4200	0.0128	x				x	x
.200	0.2	250		3.0200	0.0165	x				x	x
.250	0.25	250		2.0100	0.0355	x				x	x
.300	0.3	250		1.4050	0.0689	x				x	x
.375	0.375	250		0.8250	0.185	x				x	x
.500	0.5	250		0.4980	0.483	x				x	x
.600	.6	250		0.3620	0.880	x				x	x
.750	0.75	250		0.2445	1.84	x				x	x
001.	1	250		0.1900	0.760	x		x	x	x	x
1.25	1.25	250		0.1385	1.45	x		x	x	x	x
01.5	1.5	250		0.1036	2.35	x			x	x	x
01.6	1.6	250	0.0934	2.80	x		x	x	x	x	
1.75	1.75	250	0.0856	3.60	x			x	x	x	
01.8	1.8	250	0.0825	3.85	x			x	x	x	
002.	2	250	0.0704	5.20	x		x	x	x	x	
2.25	2.25	250	0.0594	7.20	x		x	x	x	x	
02.5	2.5	250	0.0513	9.54	x		x	x	x	x	
003.	3	250	0.0427	14.0	x		x	x	x	x	
004.	4	250	0.0293	28.5	x		x	x	x	x	
005.	5	250	0.0224	50.0	x		x	x	x	x	
006.	6	250	0.0178	118.0	x		x	x	x	x	
007.	7	250	0.0146	118.0	x		x	x	x	x	
008.	8	250	0.0122	166.0	x		x	x	x	x	
010.	10	250	0.0093	298.0	x		x	x	x	x	
012.*	12	32	300A@32 Vac	0.0072	234.6	x	x**			x	
015.*	15	32		0.0052	490.5	x	x**			x	
020.*	20	32		0.0035	1029	x	x**			x	
025.*	25	32		0.0024	2041	x	x**			x	
030.*	30	32		0.0019	3717	x	x**			x	
035.	35	32		0.0013	7531						

NOTES:

* 10mA and 31mA are not RoHS compliant as the glass bead contains Pb.

** For 318 Series 12A to 30A, the agency approval is only cURus.

Temperature Derating Curve

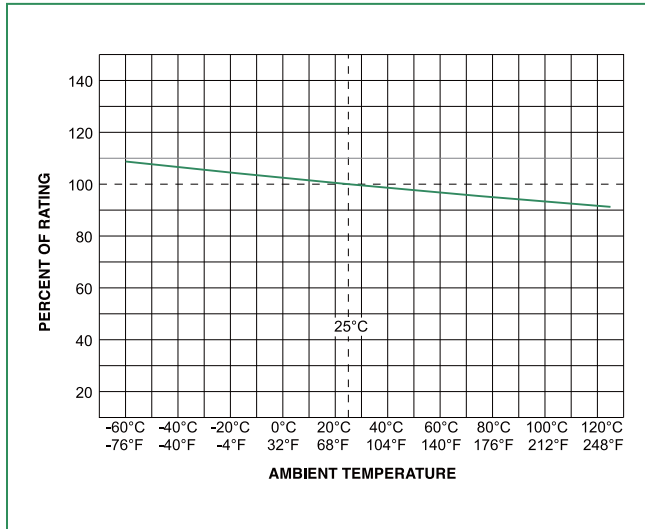

Average Time Current Curves

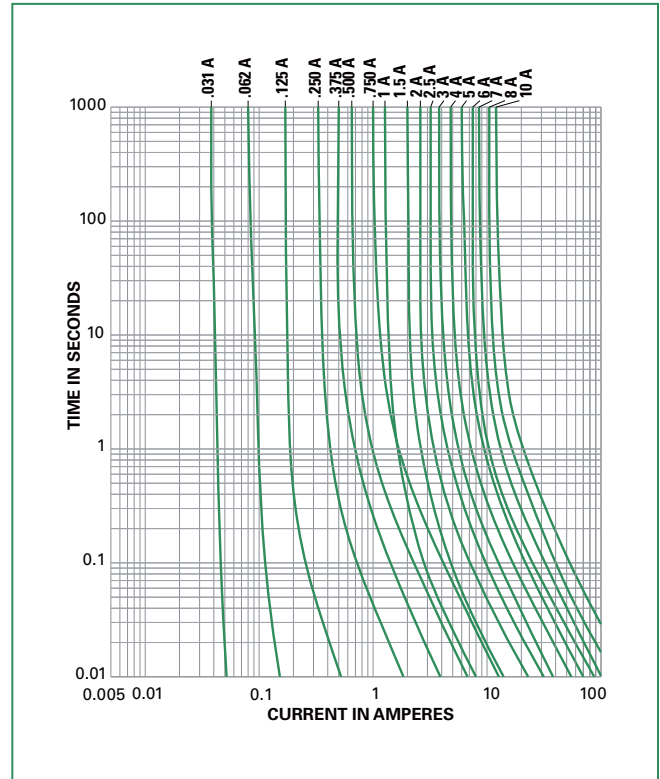

Please contact Littelfuse for more details on those T-C Curves of other ampere ratings which are not published.

Soldering Parameters - Wave Soldering

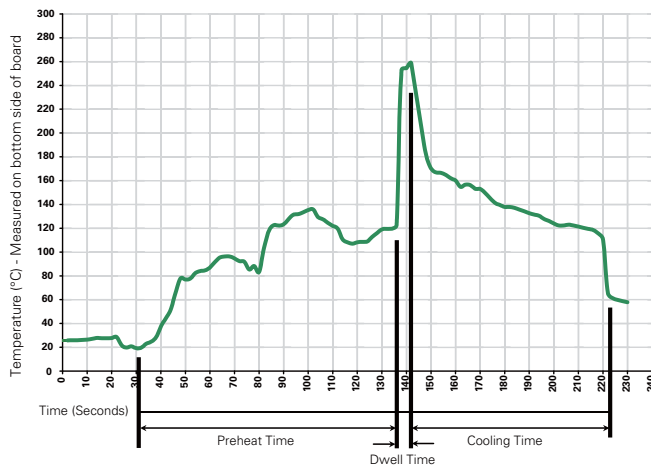

Recommended Process Parameters:

Wave Parameter	Lead-Free Recommendation
Preheat: (Depends on Flux Activation Temperature)	(Typical Industry Recommendation)
Temperature Minimum:	100° C
Temperature Maximum:	150° C
Preheat Time:	60-180 seconds
Solder Pot Temperature:	260° C Maximum
Solder Dwell Time:	2-5 seconds

Recommended Hand-Solder Parameters:

Solder Iron Temperature: 350° C +/- 5° C
 Heating Time: 5 seconds max.

Note: These devices are not recommended for IR or Convection Reflow process.

Product Characteristics

Materials	Body: Glass Cap: Nickel-plated brass Leads: Tin-plated Copper
Terminal Strength	MIL-STD-202G, Method 211A, Test Condition A
Solderability	Reference IEC 60127 Second Edition 2003-01 Annex A
Product Marking	Cap1: Brand logo, current and voltage ratings Cap2: Series and agency approval marks

Operating Temperature	-55°C to +125°C
Thermal Shock	MIL-STD-202G, Method 107G, Test Condition B: (5 cycles -65°C to +125°C)
Vibration	MIL-STD-202G, Method 201 A
Humidity	MIL-STD-202G, Method 103B, Test Condition A: High RH (95%), and Elevated temperature (40°C) for 240 hours
Salt Spray	MIL-STD-202G, Method 101D, Test Condition B

Dimensions

Measurements displayed in millimeters (inches)

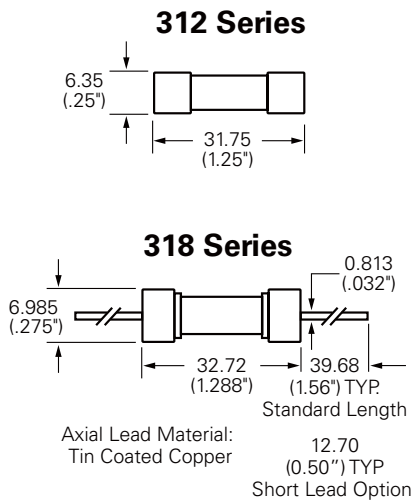

Part Numbering System

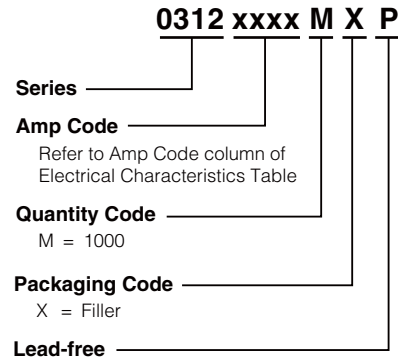

Packaging

Packaging Option	Packaging Specification	Quantity	Quantity & Packaging Code	Taping Width
312 Series				
Bulk	N/A	1000	MX	N/A
Bulk	N/A	100	HX	N/A
318 Series				
Bulk	N/A	1000	MX	N/A
Bulk	N/A	100	HX	N/A
Bulk	N/A	1000	MXB	N/A