

## Description

One, two and three pole thermal-magnetic circuit breakers with trip-free mechanism and toggle actuation (S-type TM CBE to EN 60934/IEC 934). Designed for panel or plug-in mounting. Available with auxiliary contacts (1 x N/O, 1 x N/C) for status signalling. Two and three pole models are internally linked to ensure that both/all poles trip in the event of an overload on one pole, even if the actuator is held in the ON position. A choice of characteristic curves further extends the range of applications possibilities for these CBEs. Special auxiliary contact versions for industrial atmosphere and low voltages (e.g. 5 V) available on request.

Approved to CBE standard EN 60934 (IEC 60934). Suitable for use in distribution rails – see section 7.

## Typical applications

Process control equipment, robotics, machine tool control, communications systems, instrumentation, rail vehicles. Special versions, e.g. for aggressive environmental conditions and low voltages (e.g. 5 V) on request.

## Ordering information

<b>Type No.</b>	
<b>2210</b>	single or multipole thermal-magnetic circuit breaker
<b>Mounting</b>	
<b>S</b>	socket or panel mounting
<b>Actuator design</b>	
<b>2</b>	toggle
<b>Number of poles</b>	
<b>1</b>	1-pole protected
<b>2</b>	2-pole protected
<b>3</b>	3-pole protected
<b>5</b>	2-pole, protected on one pole only
<b>Panel mounting</b>	
<b>0</b>	without hardware
<b>1</b>	with M3 thread
<b>2</b>	with 6/32 thread
<b>Terminal design (main contacts)</b>	
<b>P1</b>	blade terminals 6.3-0.8 (QC .250)
<b>Characteristic curve</b>	
<b>F1</b>	fast acting: therm. 1.01-1.4xI <sub>N</sub> ; magn. 2-4xI <sub>N</sub> DC (DC only)
<b>F2</b>	fast acting: therm. 1.01-1.4xI <sub>N</sub> ; magn. 3.5-6.5xI <sub>N</sub> AC/ 4.5-8.5xI <sub>N</sub> DC
<b>M1</b>	standard delay: therm. 1.01-1.4xI <sub>N</sub> ; magn. 6-12xI <sub>N</sub> AC; 7.8-15.6xI <sub>N</sub> DC
<b>T1</b>	delayed: therm. 1.01-1.4xI <sub>N</sub> ; magn. 10-20xI <sub>N</sub> AC
<b>T2</b>	thermal only, 1.01-1.4xI <sub>N</sub>
<b>M3</b>	standard delay, low resistance: therm. 1.4-1.8xI <sub>N</sub> ; magn. 6-12xI <sub>N</sub> AC; 7.8-15.6xI <sub>N</sub> DC
<b>Intermediate position</b>	
<b>H</b>	without intermediate position (standard)
<b>Z</b>	with intermediate position
<b>Auxiliary contacts</b>	
<b>0</b>	without auxiliary contacts
<b>1</b>	with auxiliary contacts in all poles
<b>2</b>	with auxiliary contacts in pole 1 (only multipole devices)
<b>3</b>	with auxiliary contacts in poles 1 and 3 (≥ 3-pole devices)
<b>Auxiliary contact function (see diagram)</b>	
<b>1</b>	one each N/C and N/O (standard)
<b>2</b>	one N/O contact (23/24)
<b>3</b>	one N/C contact (11/12)
<b>Auxiliary contact - terminal design</b>	
<b>1</b>	same as main terminals
<b>Current ratings</b>	
	0.1...25 A

2210 - S 2 1 0 - P1 F1 - H 1 1 1 - 10 A ordering example

Remote trip coil available to special order.



2210-S2..

## Technical data

For further details please see chapter: Technical Information

<b>Voltage rating</b>	AC 250 V*; 3 AC 433 V (50-60Hz); DC 65 V (*UL: AC 277 V; DC 65 V)				
<b>Current rating range</b>	0.1...25 A for curves M1, T1, T2 0.1...16 A for curves F1, F2, M3				
<b>Auxiliary circuit</b>	1 A, AC 240 V/DC 65 V				
<b>Typical life</b>	10,000 operations at 1 x I <sub>N</sub> , inductive				
<b>Ambient temperature</b>	-30...+60 °C (-22...+140 °F) T 60				
<b>Insulation co-ordination (IEC 60664 and 60664A)</b>	rated impulse withstand voltage	pollution degree			
	2.5 kV	2			
	reinforced insulation in operating area				
<b>Dielectric strength (IEC 60664 and 60664A)</b>	test voltage				
	operating area	AC 3,000 V			
	main/aux. circuit	AC 1,500 V			
	aux. circuit 11-12/23-24	AC 1,000 V			
	pole/pole	AC 1,500 V			
<b>Insulation resistance</b>	> 100 MΩ (DC 500 V)				
<b>Interrupting capacity I<sub>cn</sub></b>	0.1...5 A 400 A; 6...25 A 800 A curve T2 : 0.1...25 A 15 x I <sub>N</sub> curve M3: 0.1...2 A AC 200 A / DC 400 A				
<b>Interrupting capacity (UL 1077)</b>	I <sub>N</sub>	0.1...8 A	10...16 A	20...25 A	0.1...25 A
	U <sub>N</sub>	AC 250 V	AC 125 V	AC 250 V	DC 65 V
	1-pole	1,000 A	2,000 A	3,500 A	2,000 A
	2-pole	2,000 A	2,000 A	3,500 A	2,000 A
	3-pole	3AC 250V 2,000 A	3AC 250V 2,000 A	3AC 216V 3,500 A	
<b>Degree of protection (IEC 60529/DIN 40050)</b>	operating area IP30 terminal area IP00				
<b>Vibration</b>	curve F1:	3 g (57-500 Hz), ± 0.23 mm (10-57 Hz)			
	curves M1, M3, T1, T2:	5 g (57-500 Hz), ± 0.38 mm (10-57 Hz) to IEC 60068-2-6, test Fc 10 frequency cycles/axis			
<b>Shock</b>	curve F1:	25 g (11 ms), directions 1, 2, 3, 4, 5 10 g (11 ms), direction 6			
	curves M1, M3, T1, T2:	25 g (11 ms), directions 1, 2, 3, 4, 5 20 g (11 ms), direction 6 to IEC 60068-2-27, test Ea			
<b>Corrosion</b>	96 hours in 5 % salt mist to IEC 60068-2-11, test Ka				
<b>Humidity</b>	240 hours at 95 % RH to IEC 60068-2-78, test Cab				
<b>Mass</b>	approx. 50 g per pole				

2

## Standard current ratings and typical internal resistance values

Current rating (A)	Internal resistance (Ω)					
	F1 fast acting for DC only	F2 fast acting delay for AC + DC	M1 standard for AC + DC	T1 delayed low resistance nur für AC	M3 standard delay for AC + DC	T2 thermal for AC + DC
0.1	162	162	92	81	42	77
0.2	39.3	39.3	26.1	24.2	11.7	23
0.3	17.5	17.5	11.6	10.4	5.6	10.2
0.4	9.2	9.2	6,6	6.0	2.9	5.7
0.5	6.8	6.8	4,1	3.9	1.75	3.7
0.6	4.2	4.2	3	2.7	1.42	2.6
0.8	2.8	2.8	1.65	1.53	0.75	1.39
1	1.6	1.6	1,10	0.98	0.5	0.9
1.5	0.78	0.78	0.47	0.42	0.22	0.36
2	0.42	0.42	0.28	0.24	0.136	0.19
2.5	0.26	0,26	0.183	0.17	0.083	0.141
3	0.18	0.18	0.124	0.12	0.057	0.091
4	0.12	0.12	0.077	0.073	0.041	0.051
5	0.092	0.092	0.063	0.055	0.032	0.040
6	0.054	0.054	0.045	0.039	0.021	0.027
8	0.025	0.025	≤ 0.02	≤ 0.02	≤ 0.02	≤ 0.02
10	0.022	0.02	≤ 0.02	≤ 0.02	≤ 0.02	≤ 0.02
12	≤ 0.02	≤ 0.02	≤ 0.02	≤ 0.02	≤ 0.02	≤ 0.02
16	-	-	≤ 0.02	≤ 0.02	-	≤ 0.02
20	-	-	≤ 0.02	≤ 0.02	-	≤ 0.02
25	-	-	≤ 0.02	≤ 0.02	-	≤ 0.02

## Approvals

Authority	Voltage ratings	Current ratings
GL, VDE (EN 60934)	AC 250 V; DC 65 V; 3 AC 433 V	0.1...25 A
UL, CSA	AC 277 V; DC 65 V; AC 277/480 V	0.1...25 A

## Toggle positions

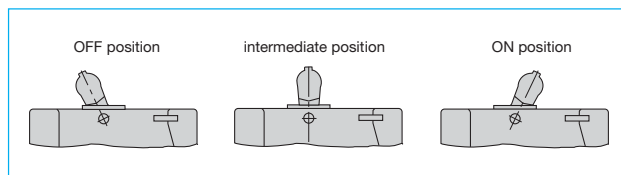

## Shock directions

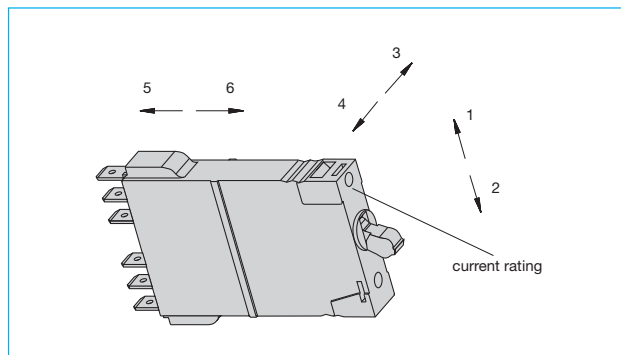

## Dimensions

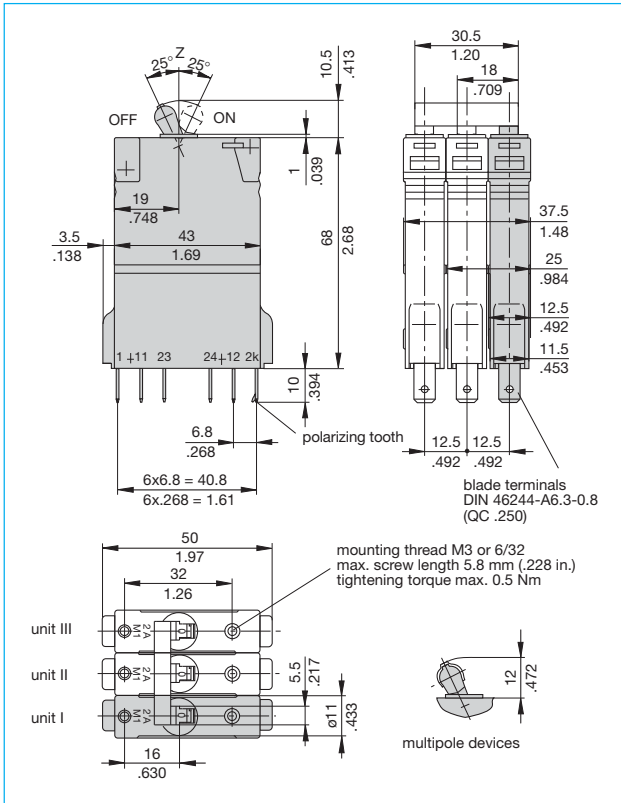

## Cut-out dimensions

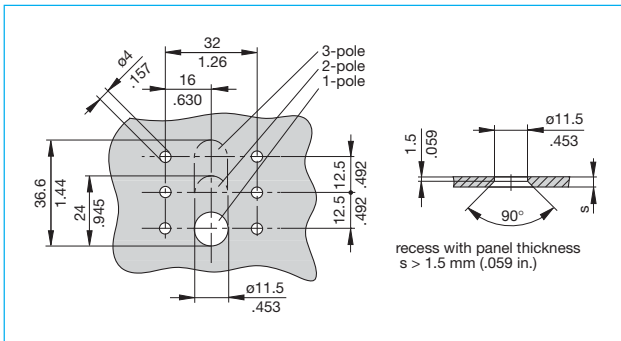

## Installation drawing

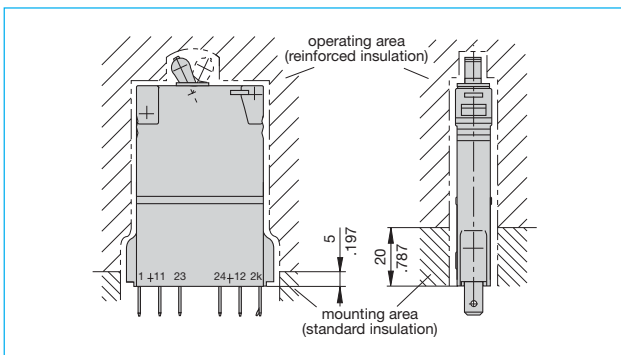

This is a type design and millimeter dimensions take precedence ( $\frac{mm}{inch}$ )

## Internal connection diagrams

**with auxiliary contact function 1** (one each N/O and N/C)  
 (...-H111-...) without intermediate position  
 (...-Z111-...) with intermediate position

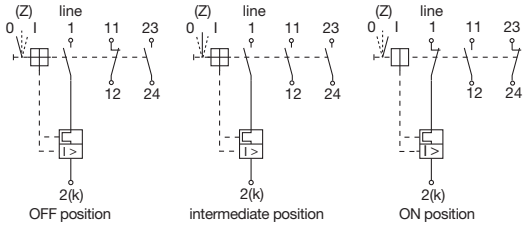

## Typical time/current characteristics

**-F1 0.1 ... 16 A** DC only

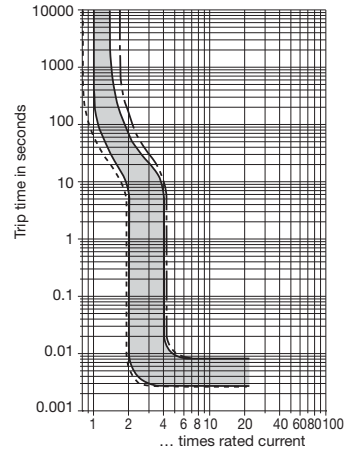

**-F2 0.1 ... 7.5 A** AC/ DC <sup>1)</sup>

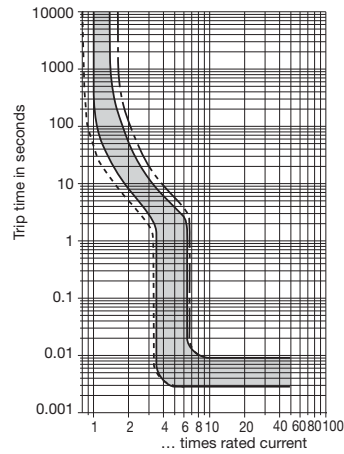

**-F2 8 ... 16 A** AC/ DC <sup>1)</sup>

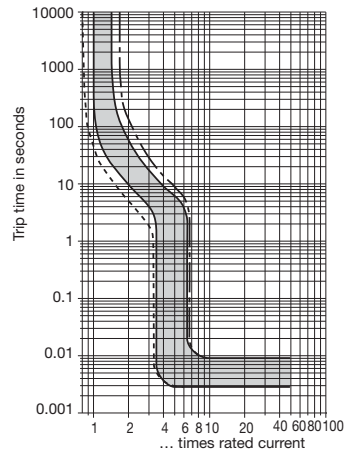

--- +60 °C / +140 °F    ——— +23 °C / +73.4 °F    - - - -30 °C / -22 °F

<sup>1)</sup> Magnetic tripping currents are increased by 30% on DC supplies.

The time/current characteristic curve depends on the ambient temperature prevailing. In order to eliminate nuisance tripping, please multiply the circuit breaker current ratings by the derating factor shown below. See also section 9 – Technical information.

Ambient temperature °F	-22	-4	+14	+32	+73.4	+86	+104	+122	+140
°C	-30	-20	-10	0	+23	+30	+40	+50	+60
Derating factor	0.76	0.79	0.83	0.88	1	1.04	1.11	1.19	1.29

Multipole devices: all poles symmetrically loaded. With single pole overload, thermal tripping will be at max.  $1.7 \times I_N$  with curves F1, F2, M1 and T2, and at max.  $2.2 \times I_N$  with curve M3.

## Typical time/current characteristics

The time/current characteristic curve depends on the ambient temperature prevailing. In order to eliminate nuisance tripping, please multiply the circuit breaker current ratings by the derating factor shown below. See also section 9 – Technical information.

Ambient temperature °F	-22	-4	+14	+32	+73.4	+86	+104	+122	+140
°C	-30	-20	-10	0	+23	+30	+40	+50	+60
Derating factor	0.76	0.79	0.83	0.88	1	1.04	1.11	1.19	1.29

Multi pole devices: all poles symmetrically loaded. With single pole overload, thermal tripping will be at max.  $1.7 \times I_N$  with curves F1, F2, M1 and T2, and at max.  $2.2 \times I_N$  with curve M3.

<sup>1)</sup> Magnetic tripping currents are increased by 30% on DC supplies (curves M1, M3, T1).

2

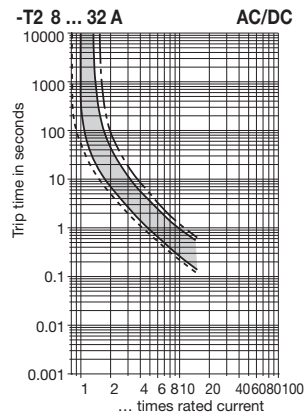
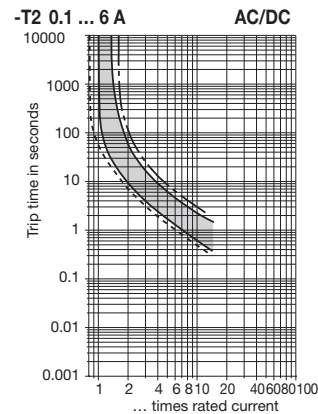
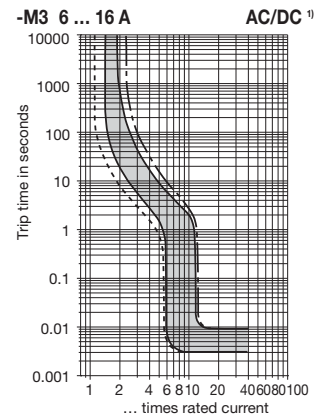
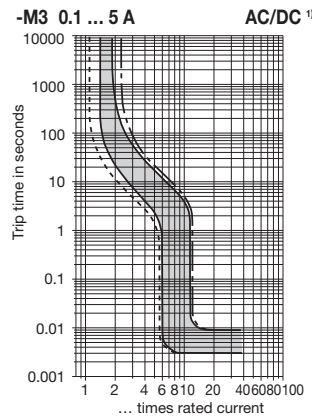
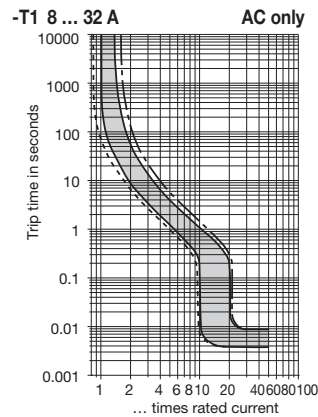
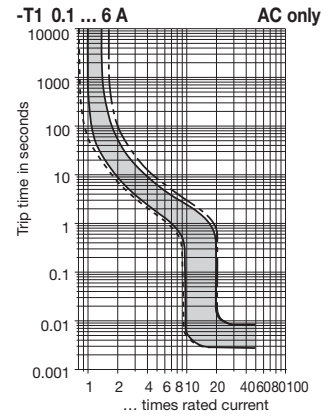
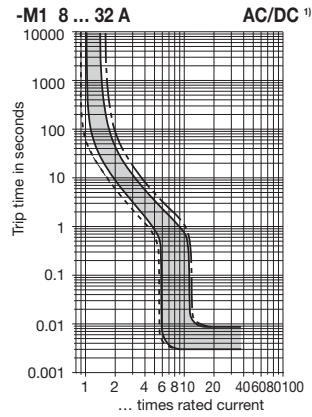
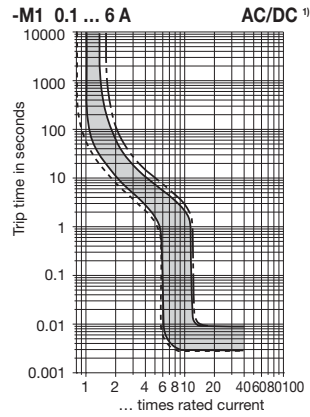

- - - +60 °C    ——— +23 °C    - - - -30 °C  
           +140 °F    +73.4 °F    -22 °F

## Accessories

### Module 17plus

For technical data see section 7 - Power distribution systems

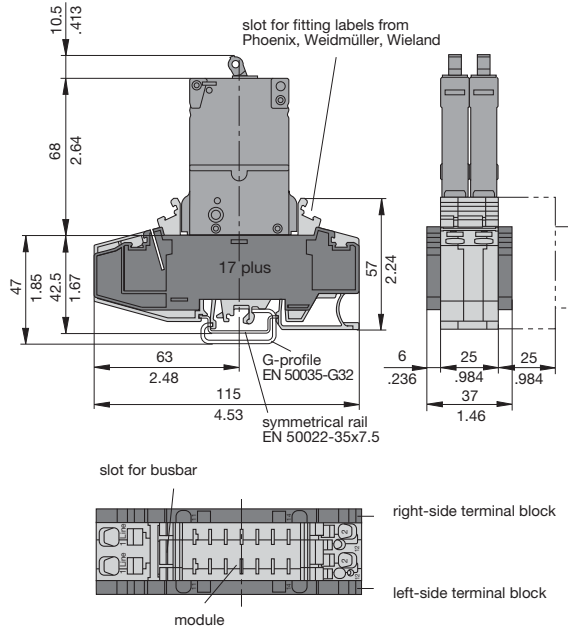

### 2-way mounting socket 23-P10-Si (up to 16 A max. load) (retaining clip Y 302 974 01 available on request)

### 6-way mounting socket 63-P10-Si

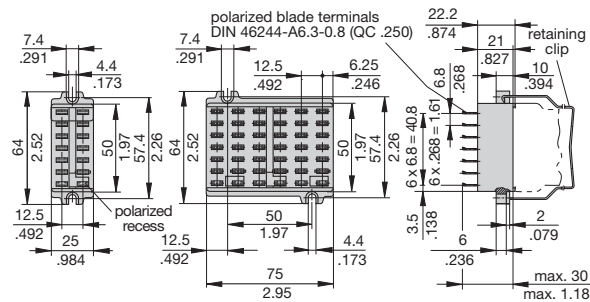

### Bus bar 50 A, 6-way, for type 63-P10-Si socket X 221 760 11

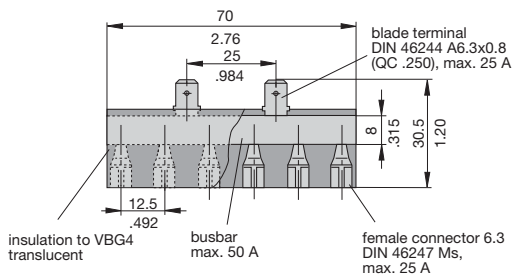

### Single mounting sockets (with adapter)

(up to 16 A max. load)

17-P10-Si 17-P10-Si-20025  
17-P70-Si 17-P70-Si-20025  
(retaining clip Y 302 974 21 available on request)

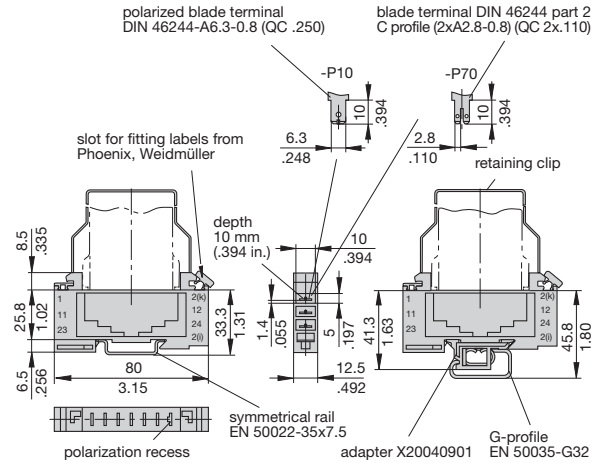

### Bus bar 50 A (6-way) for type 17-P10-Si socket X 221 760 01

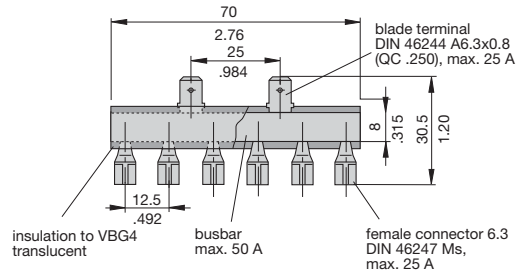

### Bus bar (10-way) (supplied as a complete package) for type 17 socket (for max. 100 A continuous load), more positions available on request X 211 157 01 with terminal X 211 157 02 without terminal

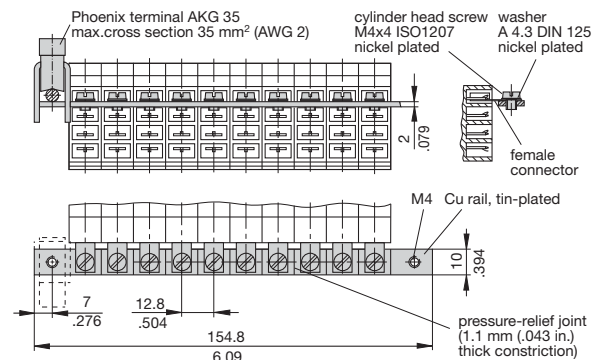

### Insulating sleeving for bus bar (10-way) Y 303 824 01

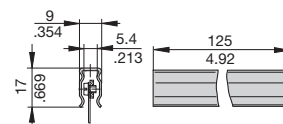

This is a metric design and millimeter dimensions take precedence ( $\frac{mm}{inch}$ )

**Accessories**

**2**

**Connector bus links -P10**

- X 210 588 01/ 1.5 mm<sup>2</sup>, (AWG 16), brown (up to 13 A max. load)
- X 210 588 02/ 2.5 mm<sup>2</sup>, (AWG 14), black (up to 20 A max. load)
- X 210 588 03/ 2.5 mm<sup>2</sup>, (AWG 14), red (up to 20 A max. load)
- X 210 588 04/ 2.5 mm<sup>2</sup>, (AWG 14), blue (up to 20 A max. load)

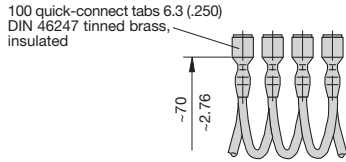

**Toggle guard for 1-pole units, black  
X 221 617 01**

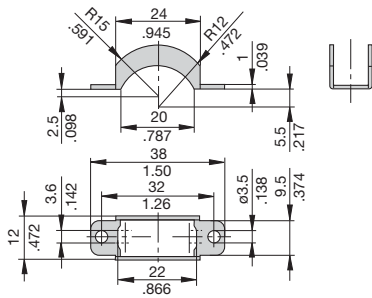

For front panel mounting.

**Splash cover (transparent)  
with fixing plate and screws (IP54)  
for type 2210-S211-... (1-pole)  
X 211 117 02**

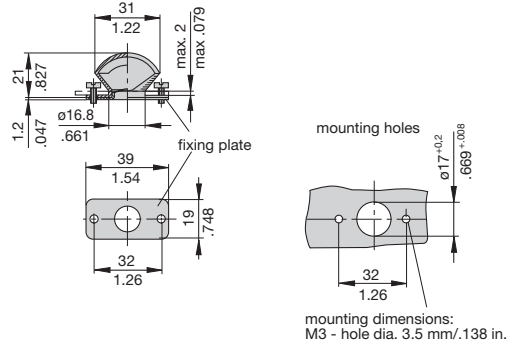

mounting dimensions:  
M3 - hole dia. 3.5 mm/.138 in.

**Splash cover (transparent)  
with fixing plate and screws (IP54)  
for type 2210-S221-... (2-pole) and  
type 2210-S231-... (3-pole)  
X 211 118 01**

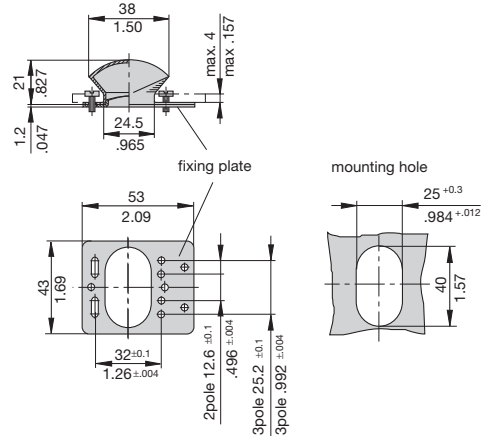

This is a metric design and millimeter dimensions take precedence ( $\frac{mm}{inch}$ )

All dimensions without tolerances are for reference only. In the interest of improved design, performance and cost effectiveness the right to make changes in these specifications without notice is reserved. Product markings may not be exactly as the ordering codes. Errors and omissions excepted.