

Description

Single pole thermal-magnetic circuit breaker with tease-free, trip-free, snap action mechanism and two button operation (M-type TM CBE to EN 60934). Designed for plug-in mounting with E-T-A sockets 17-P10-Si, 23-P10-Si, 63-P10-Si; or panel mounting using E-T-A clips. Featuring an unprotected shunt tap terminal and optional auxiliary contacts. Type 3900 offers lower internal resistance values and is fitted as standard with auxiliary contacts and an intermediate reset position in which all contacts are isolated. Approved to CBE standard EN 60934 (IEC 60934).

Typical applications

Process control systems, instrumentation, communications systems, rail vehicles.

Ordering information

Type No.	
3600	standard version with shunt tap terminal -3
3900	low-resistance version
Terminal design	
P10	blade terminals 6.3-0.8 (QC .250)
Auxiliary contacts (3900: intermediate position as standard)	
Si	with blade terminals 6.3-0.8, one each NO/NC,
Si60	special auxiliary contact (only 3900)
	1 NO, closed in the intermediate and ON position
ZR-Si	auxiliary contacts with intermediate position (only 3600)
ZR-Si60	special auxiliary contact (only 3600)
	1 NO, closed in the intermediate and ON position
Si3-R	special auxiliary contacts, 2 NC contacts with reset button (not approved)
Current ratings	
	0.05...16 A (type 3600)
	0.05...10 A (type 3900)
3600 - P10 - Si - 10 A ordering example	

The exact part number required can be built up from the table of choices shown above. Ordering references for optional features should be omitted if not required.

Standard current ratings and typical internal resistance values

Current rating (A)	Internal resistance (Ω)		Current rating (A)	Internal resistance (Ω)	
	3600	3900		3600	3900
0.05	447	211	3	0.19	0.054
0.1	131	48	4	0.090	0.035
0.2	40	12.4	5	0.061	0.025
0.3	19.3	5.4	6	0.041	≤ 0.02
0.4	10.4	3.1	7	0.034	≤ 0.02
0.5	7.1	2.0	8	≤ 0.02	≤ 0.02
0.6	4.3	1.32	10	≤ 0.02	≤ 0.02
0.8	2.5	0.76	12	≤ 0.02	
1	1.67	0.49	14	≤ 0.02	
1.5	0.61	0.21	15	≤ 0.02	
2	0.38	0.101	16	≤ 0.02	
2.5	0.24	0.078			



3600
standard type

3900
low-resistance type

Technical data

For further details please see chapter: Technical Information

Voltage rating	AC 240 V, 50/60 Hz; DC 65 V (UL: AC 250 V; DC 65 V)		
Current rating range	3600: 0.05...16 A 3900: 0.05...10 A		
Auxiliary circuit	1 A, AC 240 V / DC 65 V		
Typical life	5,000 operations at 1 x I _N , inductive 5,000 operations at 2 x I _N , resistive		
Ambient temperature	-30...+60 °C (-22...+140 °F)		
Insulation co-ordination (IEC 60664 and 60664 A)	rated impulse withstand voltage 2.5 kV	pollution degree 2	reinforced insulation in operating area
Dielectric strength (IEC 60664 and 60664A)	test voltage operating area main/aux. circuit aux. circuit 4-5/6-7	AC 3,000 V AC 1,500 V AC 840 V	
Insulation resistance	>100 MΩ (DC 500 V)		
Interrupting capacity I _{cn}	3600 0.05...0.8 A 1...2 A 2.5...16 A	3900 0.05...0.2 A 0.3...2 A 2.5...10 A	self-limiting 200 A 400 A
Interrupting capacity (UL 1077)	I _N 0.05...16 A type 3600: 0.05...16 A	U _N AC 250 V DC 80 V	1,000 A 1,000 A
Degree of protection (IEC 60529/DIN 40050)	operating area IP40 terminal area IP00		
Vibration	5 g (57-500 Hz), ± 0.38 mm (10-57 Hz) to IEC 60068-2-6, test Fc 10 frequency cycles/axis		
Shock	25 g (11 ms) to IEC 60068-2-27, test Ea		
Corrosion	96 hours at 5 % salt mist to IEC 60068-2-11, test Ka		
Humidity	240 hours at 95 % RH to IEC 60068-2-78, test Cab		
Mass	approx. 45 g		

Approvals

Authority	Voltage ratings	Current ratings
3600:		
VDE (EN 60934)	AC 240 V; DC 65 V	0.05...16 A
CSA/UL	AC 250 V; DC 80 V	0.05...16 A
UL	DC 65 V	0.05...25 A
3900:		
VDE (EN 60934)	AC 240 V; DC 65 V	0.05...10 A

Dimensions

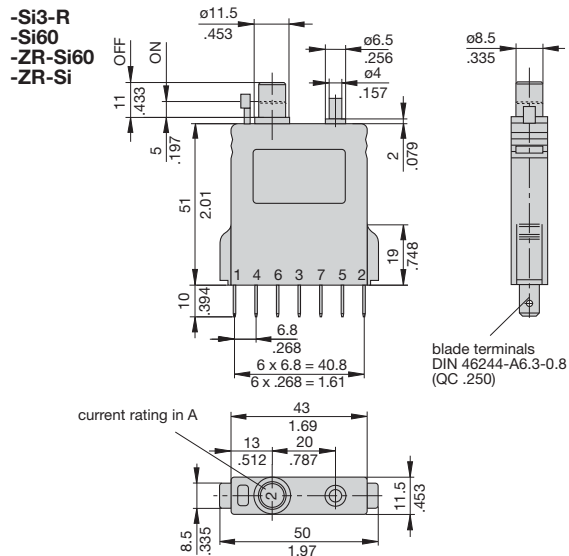
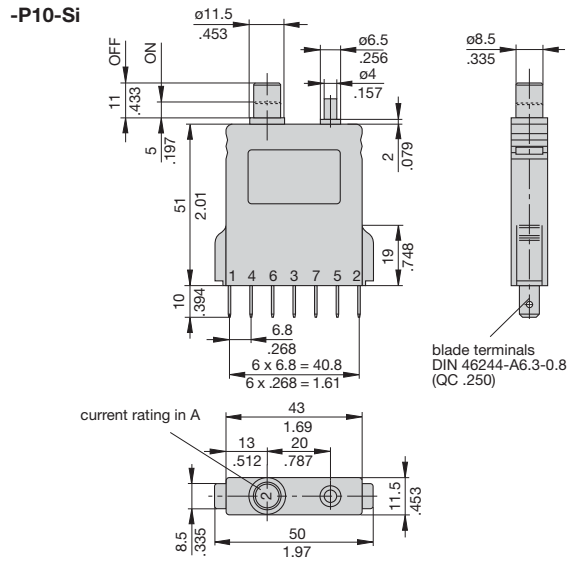

Intermediate position: Holding down reset button and actuating manual release simultaneously.

Installation drawing

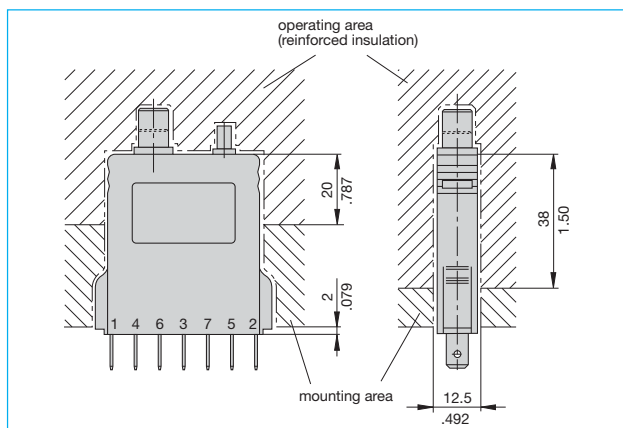

Internal connection diagrams

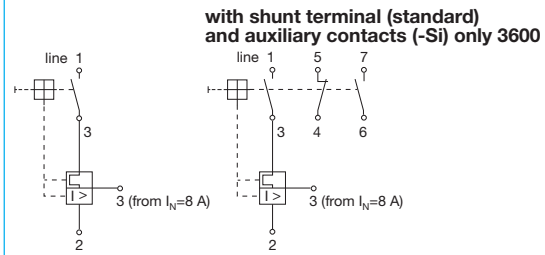

Switching position with auxiliary contacts and reset button (-Si3-R)

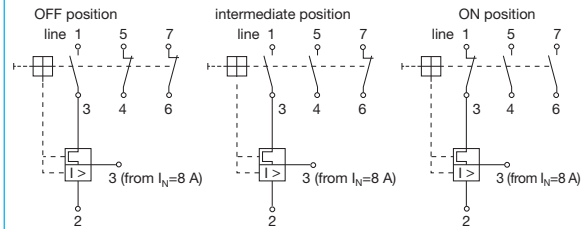

Switching position with special auxiliary contact (-Si60, -ZR-Si60)

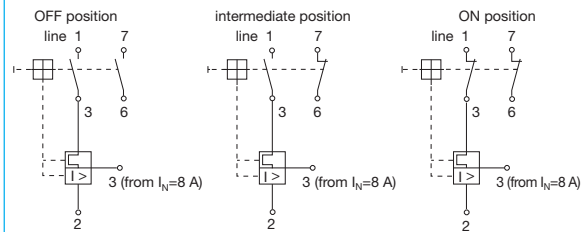

Switching position with intermediate position and auxiliary contacts (3600: -ZR-Si, 3900: -Si)

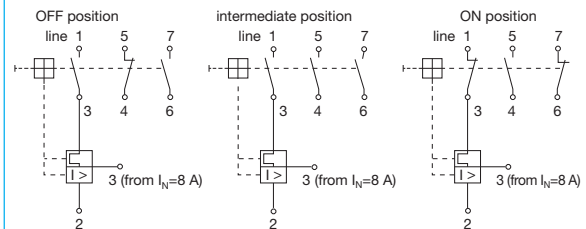

Terminal design -P10

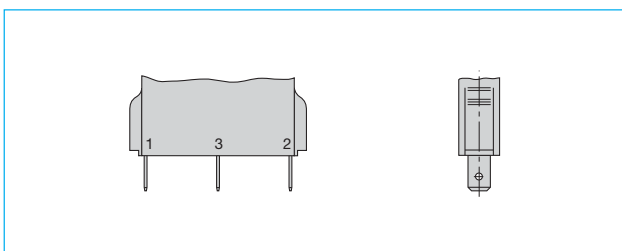

This is a metric design and millimeter dimensions take precedence ($\frac{mm}{inch}$)

Typical time/current characteristics

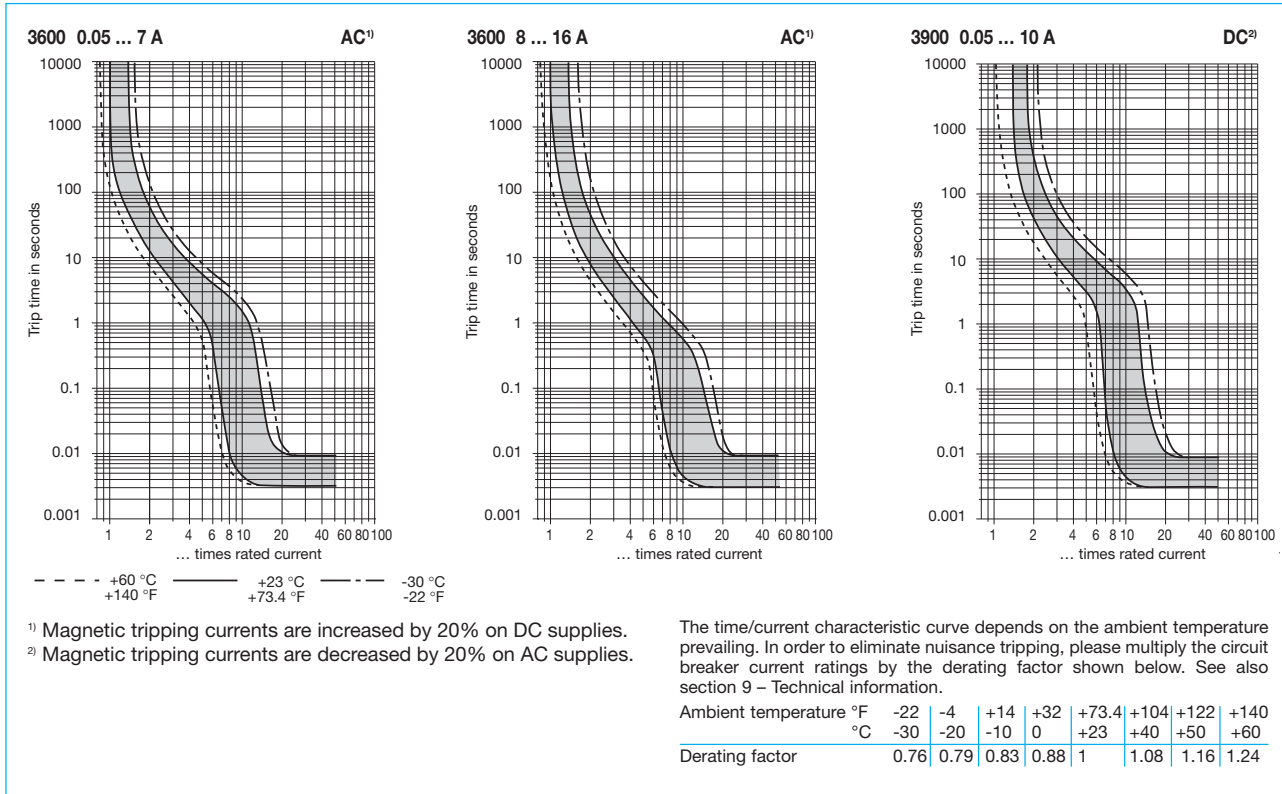

2

Accessories

Module 17plus

Modular power distribution system for circuit breakers 2210-S, 3600 or 3900.

For technical details see product group 7.

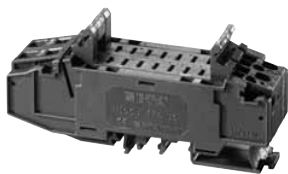

Power-D-Box with sockets

accommodating up to 30 E-T-A thermal-magnetic circuit breakers type 3600-P10-Si or 3900-P10-Si.

For technical data see product group 7.

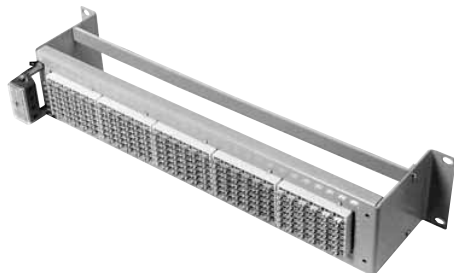

Power-D-Box with sockets pre-wired 19BGT2 2U

for 18, 24 or 30 circuits.

For technical data see product group 7.

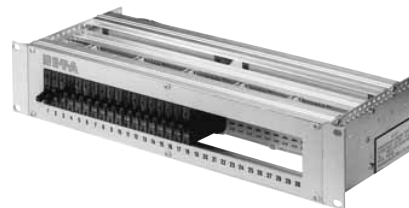

Accessories

2

Sockets

17-P10-Si

(up to 16 A max. load)

Retaining clip Y 300 581 11 to special order.

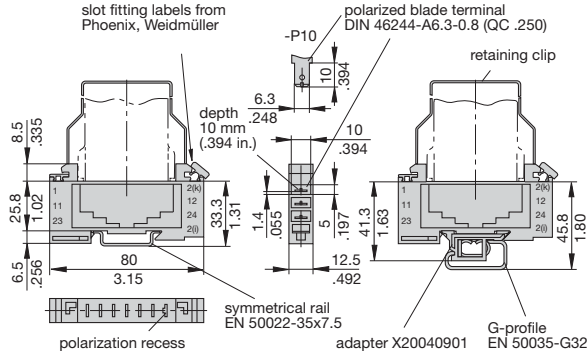

17-P10-Si-20025

mounted with adapter

Retaining clip Y 300 581 11 to special order.

Sockets

17-P70-Si

(up to 16 A max. load)

Retaining clip Y 300 581 11 to special order.

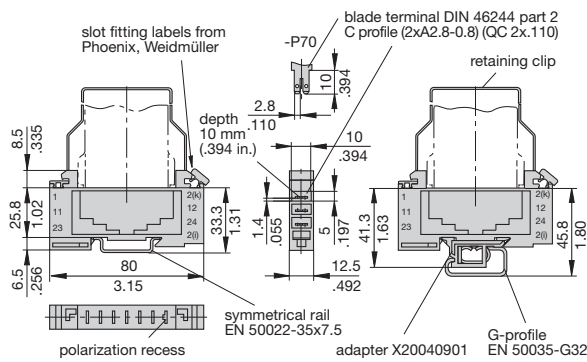

17-P70-Si-20025

mounted with adapter

Retaining clip Y 300 581 11 to special order.

Sockets

23-P10-Si

(up to 16 A max. load)

Retaining clip Y 300 581 03 to special order.

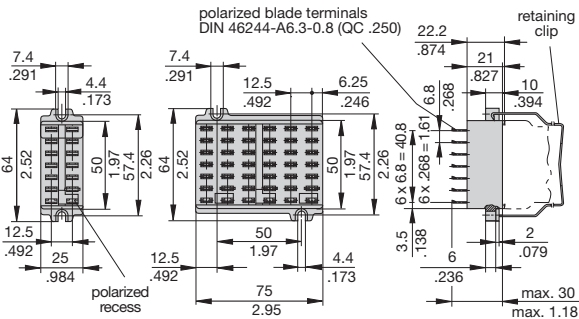

63-P10-Si

(up to 16 A max. load)

Retaining clip Y 300 581 03 to special order.

Bus bar (10-way) (supplied as a complete package)

for socket 17 (for max. 100 A continuous load)

X 211 157 01 with terminal

X 211 157 02 without terminal

(more positions available on request)

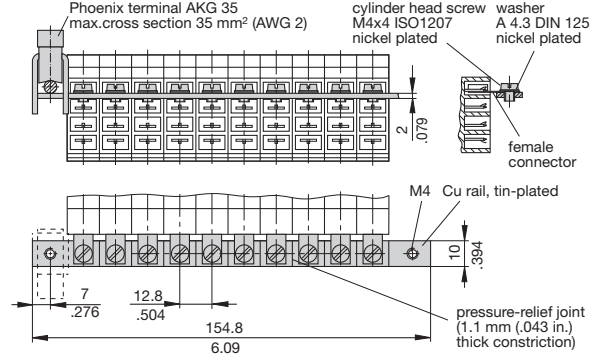

Insulate sleeving for bus bar

Y 303 824 01

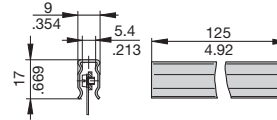

Connector bus links -P10

X 210 588 01/ 1.5 mm² (AWG 16), brown up to 13 A max. load

X 210 588 02/ 2.5 mm² (AWG 14), black up to 20 A max. load

X 210 588 03/ 2.5 mm² (AWG 14), red up to 20 A max. load

X 210 588 04/ 2.5 mm² (AWG 14), blue up to 20 A max. load

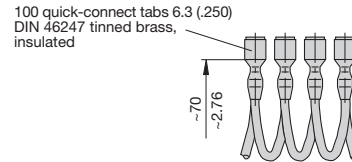

Extraction tool

Y 301 398 02

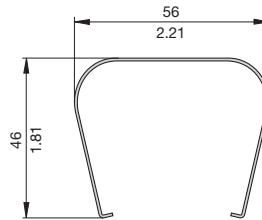

Mounting clip

Y 300 504 02

(2 pcs needed per unit)

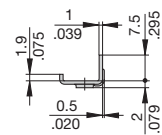

Installation drawing with mounting clips Y 300 504 02

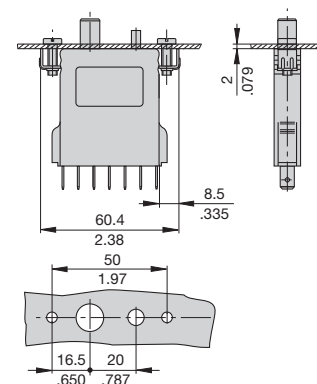

This is a metric design and millimeter dimensions take precedence (mm/inch)

All dimensions without tolerances are for reference only. In the interest of improved design, performance and cost effectiveness the right to make changes in these specifications without notice is reserved. Product markings may not be exactly as the ordering codes. Errors and omissions excepted.