

Description

Miniaturised single pole rocker switch/thermal circuit breaker combining ON/OFF switching and extremely fast overload performance in a single component (S-type TO CBE to EN 60934/IEC 934). Under overload conditions an internal neon (filament bulb for low voltages) illuminates to give a clear signal of the tripped status of the mechanism and thereby the cause of power interruption, suffix -B. Alternatively the illumination can be conventionally wired to indicate the ON status of the device, suffix -E. Returning the rocker switch through the OFF position and back ON will reset the mechanism and restore the supply. Largely temperature-insensitive. Complies with CBE standard EN 60934 (IEC 60934).

Typical applications

Motors, transformers, solenoids, PCBs, hand-held machines, appliances, instrumentation.

Ordering information

Type No.	
1410	snap-in panel mounting type
Mounting	
F	snap-in panel mounting
Size of frame	
1	to fit mounting cut-out 28 x 12.7 mm (1.1 x .5 in)
Number of poles	
1	single pole, thermally protected
Accessories	
0	without accessories
Terminal design	
P1	blade terminals 2.8-0.8 (QC .110/2x.110) silver-plated
Characteristic curve	
F1	fast acting
Actuator style	
W	rocker, rounded profile
Actuator colour	
02	white opaque
14	red translucent
15	orange translucent
19	green translucent
Actuator markings	
Q	I and O
Trip/ON illumination (optional)	
B	illuminated when tripped
E	illuminated when ON
Illumination voltage range (optional)	
2	20-28 V marked 24 V 35 mA
3	90-140 V marked 115 V < 1 mA
4	185-275 V marked 230 V < 1 mA
Current ratings	
0.63...10 A	
1410 - F 1 1 0 - P1 F1 - W 14 Q E 3 - 2 A ordering example	

The exact part number required can be built up from the table of choices shown above. Ordering references for optional features should be omitted if not required.

Standard current ratings and typical internal resistance values

Current rating (A)	Internal resistance (Ω)	Current rating (A)	Internal resistance (Ω)
0.63	1.8	3.15	< 0.12
0.8	1.7	4	< 0.1
1	1.3	5	< 0.1
1.5	< 1	6.3	< 0.1
1.8	< 1	8	< 0.1
2	< 1	10	< 0.1
2.5	< 0.15		



1410-F1..

Technical data

Voltage rating	AC 240 V; DC 28 V (DC 50 V upon request) (UL: AC 250 V; DC 48)	
Current rating range	0.63...10 A	
Typical life	30,000 operations for $I_N \leq 6.3$ A AC/DC 10,000 operations for $I_N > 6.3$ A AC 3,000 operations for $I_N > 6.3$ A DC	
protection circuit 1-2	300 break operations at $2 \times I_N$	
Ambient temperature	-20...+70 °C (-4...+158 °F)	
Insulation co-ordination (IEC 60664 and 60664 A)	rated impulse withstand voltage 2.5 kV	pollution degree 2
	reinforced insulation in operating area	
Dielectric strength (IEC 60664 and 60664A) operating area	test voltage AC 3,000 V	
Insulation resistance	> 100 MΩ (DC 500 V)	
Interrupting capacity I_{cn}	0.63...2 A	$12 \times I_N$
	2.5...8 A	$8 \times I_N$, AC max. 50 A
	10 A	$6 \times I_N$
	3.15...10 A	$10 \times I_N$, DC
Interrupting capacity (UL 1077)	0.63...10 A	2,000 A AC 250 V
	0.63...8 A	200 A DC 50 V
	0.63...5 A	200 A DC 60 V
Degree of protection (IEC 60529/DIN 40050)	operating area IP30 terminal area IP00	
Vibration	8 g (57-500 Hz) \pm 0.61 mm (10-57 Hz), to IEC 60068-2-6, test Fc, 10 frequency cycles/axis	
Shock	20 g (11 ms) to IEC 60068-2-27, test Ea	
Corrosion	48 hours at 5 % salt mist, to IEC 60068-2-11, test Ka	
Humidity	96 hours at 95 % RH to IEC 60068-2-78, test Cab	
Mass	approx. 9 g	

Approvals

Authority	Voltage ratings	Current ratings
UL, CSA	AC 250 V DC 50 V	0.63...10 A 0.63...8 A
UL	DC 60 V	0.63...5 A

1

Dimensions

1410-F...-...-...B.

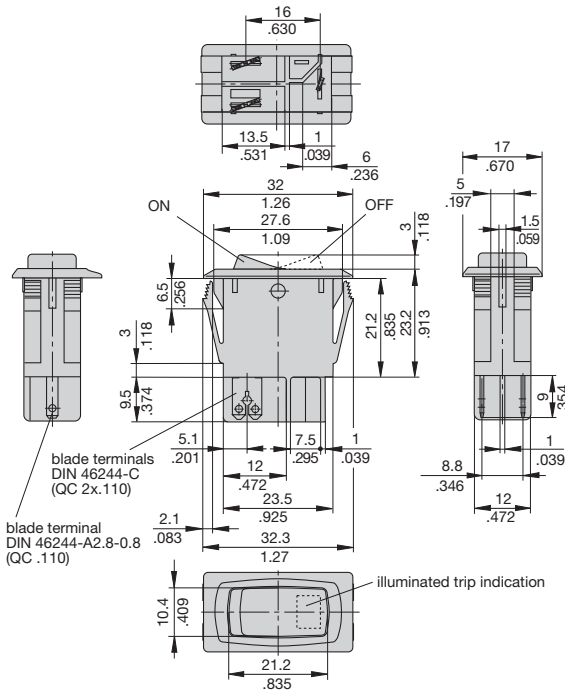

1410-F...-...-...E.

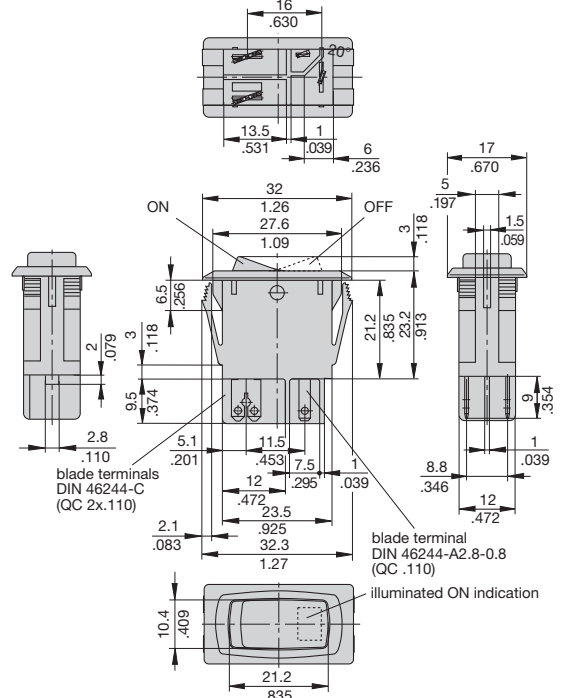

panel cut-out

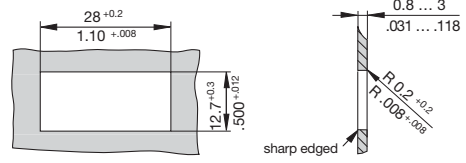

Internal connection diagrams

1410-F...-...-...B.

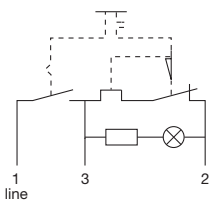

1410-F...-...-...E.

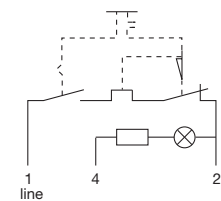

lamp current:
24 V = 35 mA
115 V < 1 mA
230 V < 1 mA

Typical time/current characteristics at +23 °C/+73.4 °F

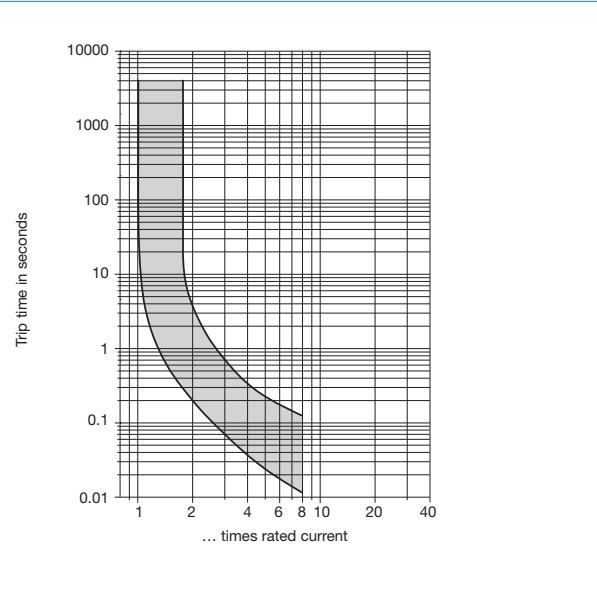

Installation drawing

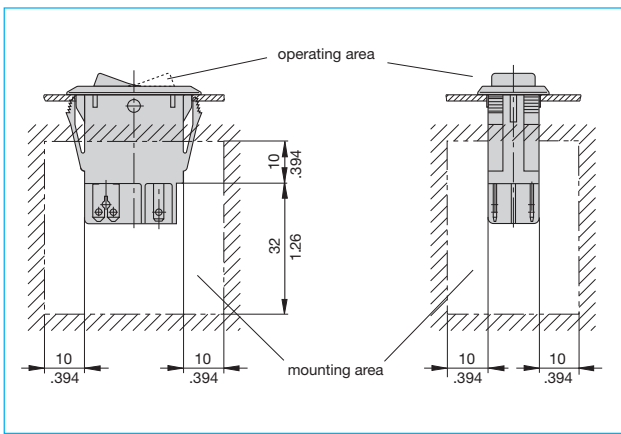

This is a metric design and millimeter dimensions take precedence (mm/inch)

All dimensions without tolerances are for reference only. In the interest of improved design, performance and cost effectiveness the right to make changes in these specifications without notice is reserved. Product markings may not be exactly as the ordering codes. Errors and omissions excepted.