

## Description

Miniaturised single pole thermal circuit breaker with push-to-reset, tease-free, trip-free, snap action mechanism (R-type TO CBE to EN 60934). Available in versions for PCB or panel mounting, snap-in or threadneck, or as an integral type. Manual release facility optional for type 105.

Approved to CBE standard EN 60934 (IEC 60934). For higher current ratings see type 1140.

## Typical applications

Motors, transformers, solenoids, printed circuit boards, hand-held machines and appliances, marine applications, caravans.

## Ordering information

### Type No.

<b>104</b>	PCB mounting type (-PR), or integral type (-P30/P10)
<b>105</b>	snap-in panel mounting
<b>106</b>	threadneck panel mounting with hex and knurled nut*
<b>106-M2</b>	threadneck panel mounting 3/8-27UNS with collar, hex nut and knurled nut*

### Terminal design

<b>P10</b>	blade terminals A6.3-0.8 (QC .250)
<b>P30</b>	blade terminals A2.8-0.8 (QC .110)
<b>PR</b>	solder terminal pins for PCB mounting (type 104 only)
<b>PR2</b>	PCB mounting (vertical), type 104 only up to 6 A
<b>PR3</b>	PCB mounting (vertical), type 104 only

### Shunt terminal (optional)

**A3** same as main terminals (up to  $I_N$  6 A/3 A max. load)

### Manual release facility (optional)

**H** only with type 105

### Auxiliary contacts (optional)

**Si51** type 104 only

### Current ratings

**0.05...10 A**

**106 - P30 - .. - .. - .. - 5 A = ordering example**

The exact part number required can be built up from the table of choices shown above. Ordering references for optional features should be omitted if not required.

\* mounting hardware bulk shipped

## Standard current ratings and typical internal resistance values

Current rating (A)	Internal resistance ( $\Omega$ )	Current rating (A)	Internal resistance ( $\Omega$ )
0.05	285	1.8	0.28
0.08	134	2	0.25
0.1	81	2.5	0.18
0.2	22	3	0.11
0.3	8.7	3.5	0.076
0.4	5.5	4	0.067
0.5	3.3	4.5	0.051
0.6	2.45	5	$\leq 0.05$
0.7	1.6	6	$\leq 0.05$
0.8	1.45	7	$\leq 0.05$
1	0.9	8	$\leq 0.05$
1.2	0.6	10	$\leq 0.05$
1.5	0.4		

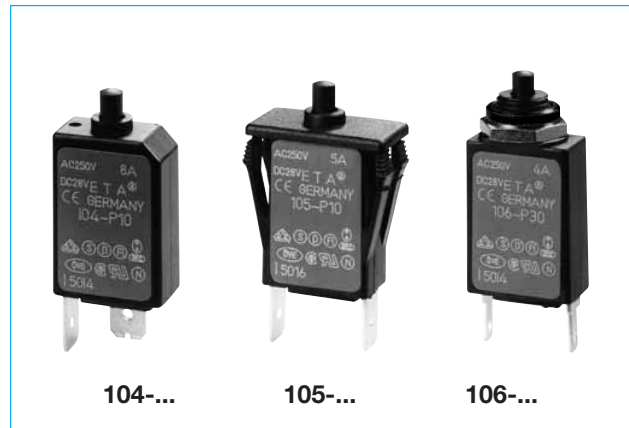

## Technical data

For further details please see chapter: Technical Information

Voltage rating	AC 240 V; DC 48 V (UL: AC 250 V; DC 48 V)	
Current ratings	0.05...10 A	
Auxiliary circuit	0.5 A, AC 240 V, DC 28 V	
Typical life	AC 240 V	
	0.05...8 A	2,000 operations at $1 \times I_N$ , inductive
	0.05...5 A	3,000 operations at $2 \times I_N$ , inductive
	6...8 A:	500 operations at $2 \times I_N$ , inductive
DC 48 V	0.05...8 A	2,000 operations at $1 \times I_N$ , inductive
	0.05...5 A	3,000 operations at $2 \times I_N$ , inductive
	6...8 A:	500 operations at $2 \times I_N$ , inductive
	10 A	200 operations at $1 \times I_N$ , inductive
	10 A	50 operations at $2 \times I_N$ , inductive
Ambient temperature	-20...+60 °C (-4...+140 °F) T 60	
Insulation co-ordination (IEC 60664 and 60664 A)	rated impulse withstand voltage	pollution degree
	2.5 kV	2
	reinforced insulation in operating area	
Dielectric strength (IEC 60664 and 60664 A)	test voltage	
	operating area AC 3,000 V	
Insulation resistance	> 100 M $\Omega$ (DC 500 V)	
Interrupting capacity $I_{cn}$	0.05...8 A	$6 \times I_N$ AC
	> 8...10 A	$5 \times I_N$ AC
	0.05...10 A	$6 \times I_N$ DC
Interrupting capacity (UL 1077)	$I_N$	$U_N$
	0.05...10 A	AC 250 V 2,000 A
	0.05...10 A	DC 48 V 200 A
Degree of protection (IEC 60529/DIN 40050)	operating area IP40	
	terminal area IP00	
Vibration	10 g (57-500 Hz) $\pm$ 0.76 mm (10-57 Hz), to IEC 60068-2-6, test Fc, 10 frequency cycles/axis	
Shock	25 g (11 ms) to IEC 60068-2-27, test Ea	
Corrosion	96 hours at 5 % salt mist, to IEC 60068-2-11, test Ka	
Humidity	240 hours at 95 % RH, to IEC 60068-2-78, test Cab	
Mass	approx. 10 g	

## Approvals

Authority	Voltage ratings	Current ratings
VDE, SEV,	AC 240 V	0.05...8 A
Kema (EN 60934)	DC 48 V	0.05...10 A
CSA, UL	AC 250 V; DC 48 V	0.05...10 A

Circuit breakers with -Si51 not approved

## Dimensions

### 104-P30

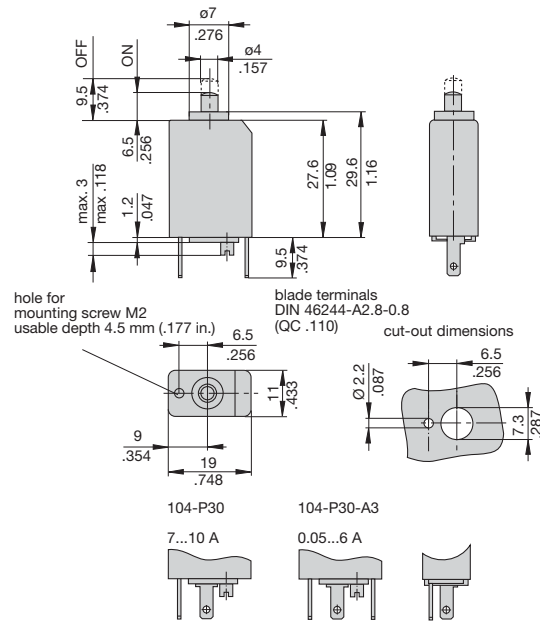

### 104-PR-(A3)-Si51

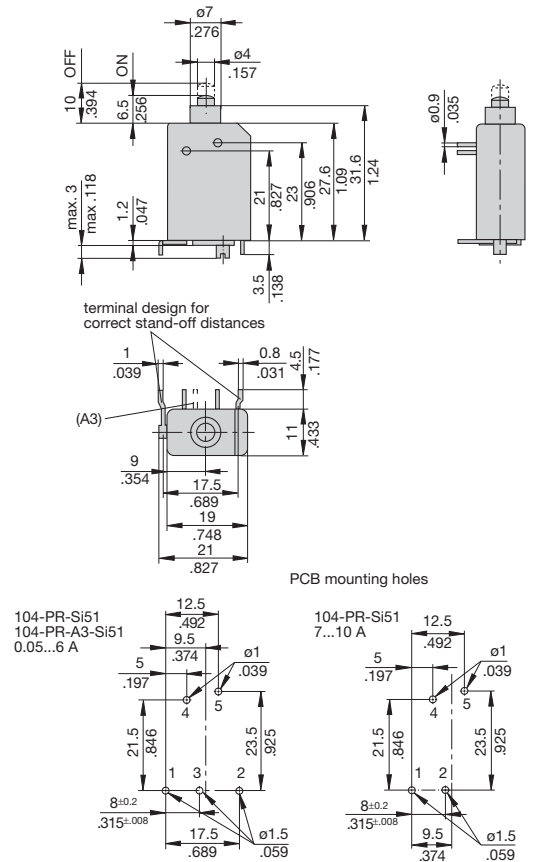

### 104-PR

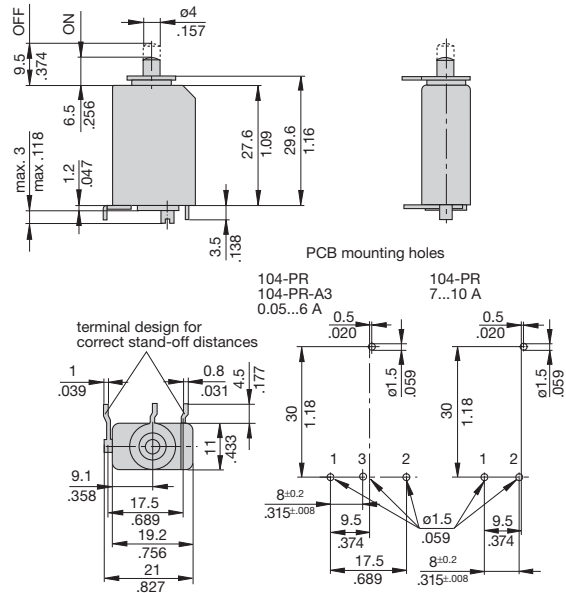

### 104-PR3

0.05...6 A

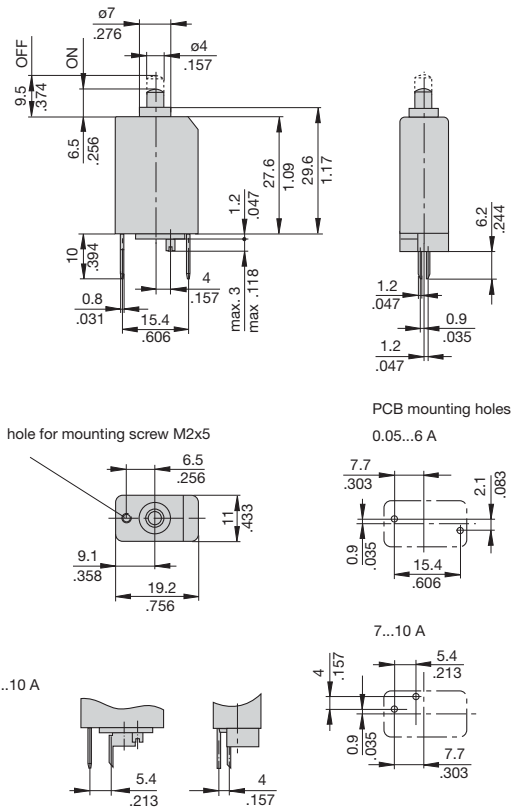

This is a metric design and millimeter dimensions take precedence (mm/inch)

## Dimensions

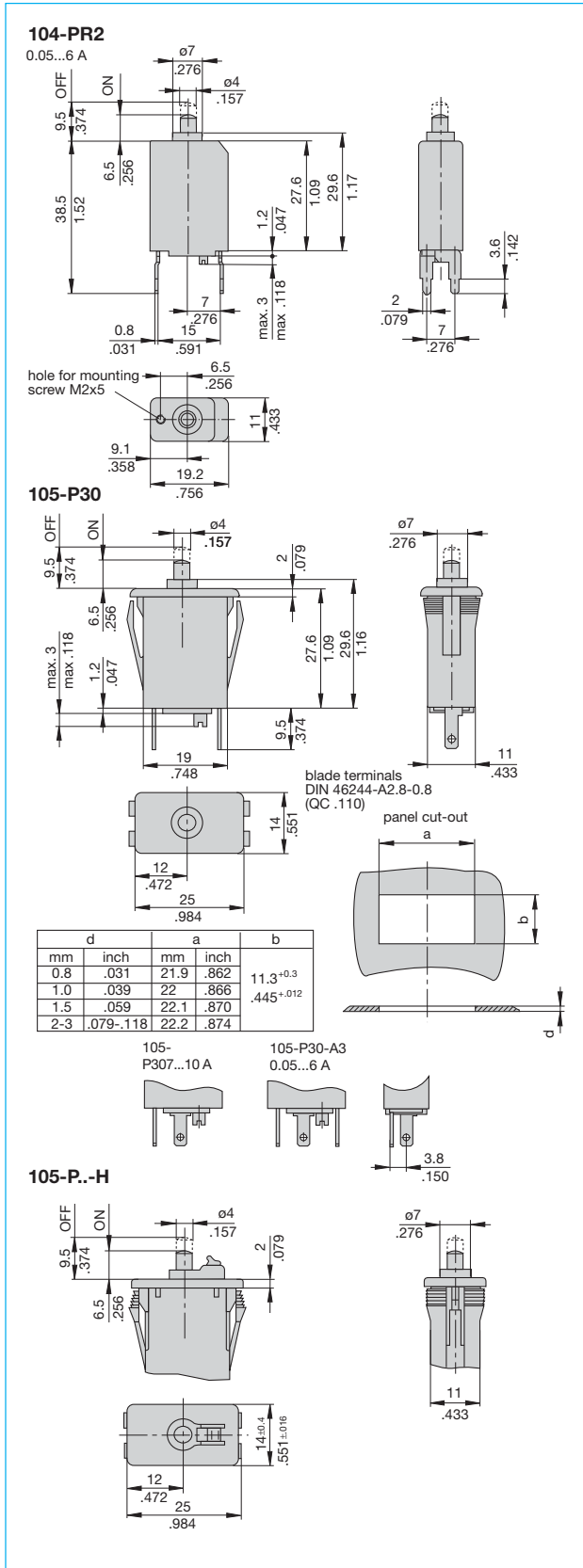

This is a metric design and millimeter dimensions take precedence ( $\frac{mm}{inch}$ )

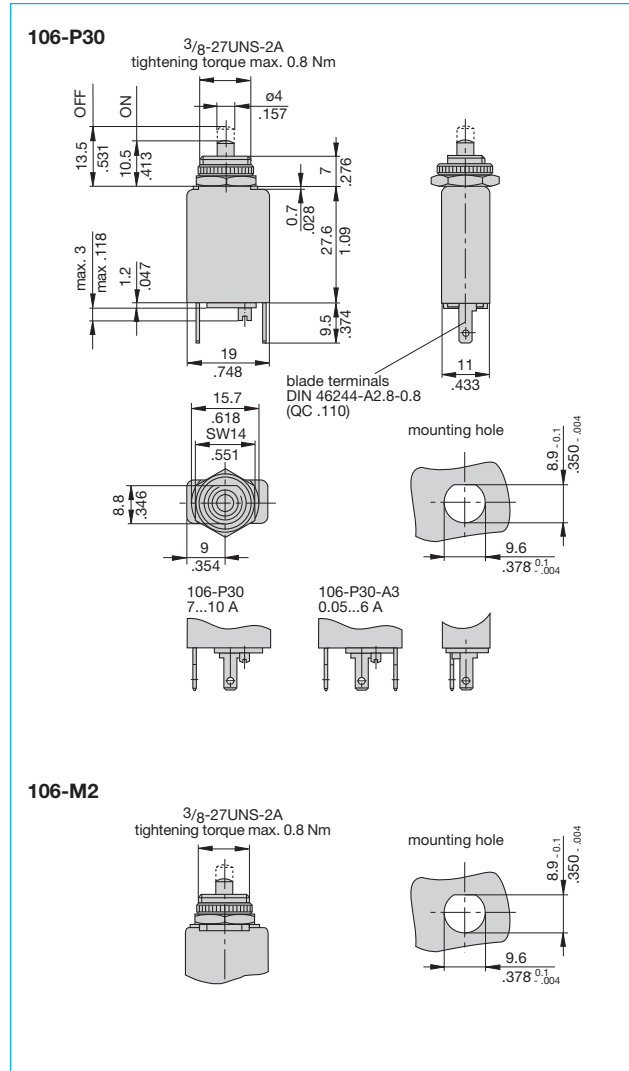

## Terminal design

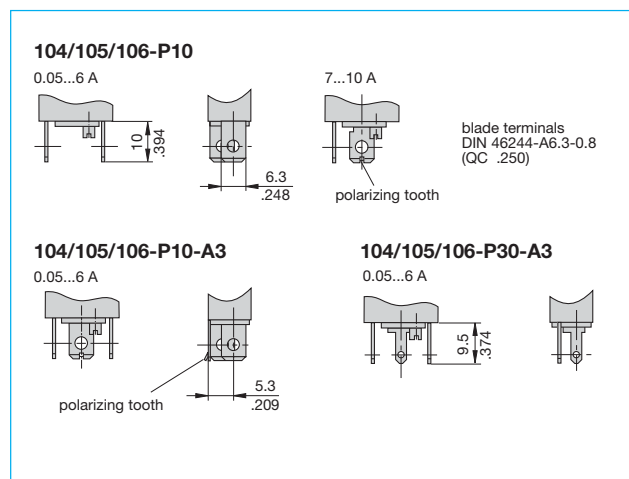

1

## Installation drawings

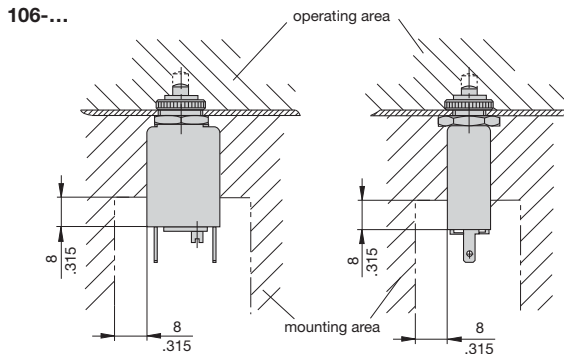
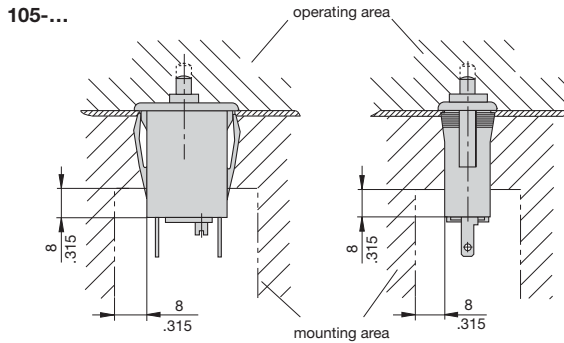
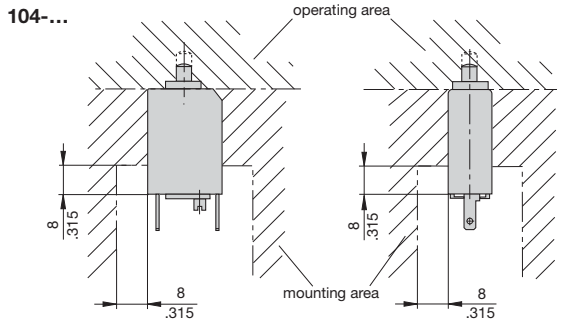

## Internal connection diagrams

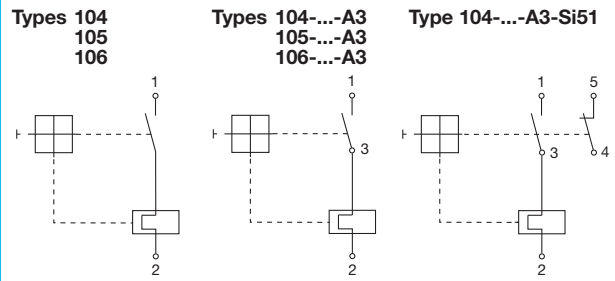

## Typical time/current characteristics at +23 °C/+73.4 °F

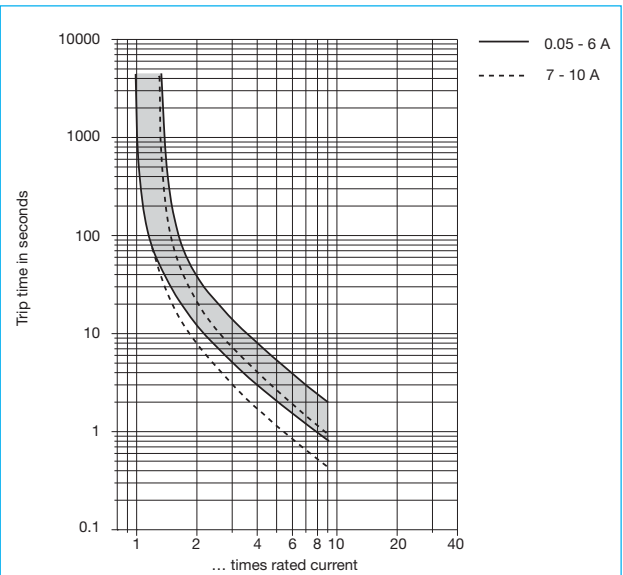

The time/current characteristic curve depends on the ambient temperature prevailing. In order to eliminate nuisance tripping, please multiply the circuit breaker current ratings by the derating factor shown below. See also section 9 – Technical information.

Ambient temperature °F	-4	+14	+32	+73.4	+104	+122	+140
°C	-20	-10	0	+23	+40	+50	+60
Derating factor	0.76	0.84	0.92	1	1.08	1.16	1.24

## Accessories

**Water splash cover (transparent)/knurled nut assembly**  
 (type 106-... only)  
**X 201 285 01**  
 Degree of protection IP64

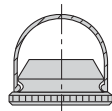

This is a metric design and millimeter dimensions take precedence ( $\frac{mm}{inch}$ )

All dimensions without tolerances are for reference only. In the interest of improved design, performance and cost effectiveness the right to make changes in these specifications without notice is reserved. Product markings may not be exactly as the ordering codes. Errors and omissions excepted.