

LITTELFUSE PART #	REELED	WIRE GAGE
913-042	YES	10
913-042-001	NO	10
913-043	YES	14
913-043-001	NO	14
913-044	YES	18

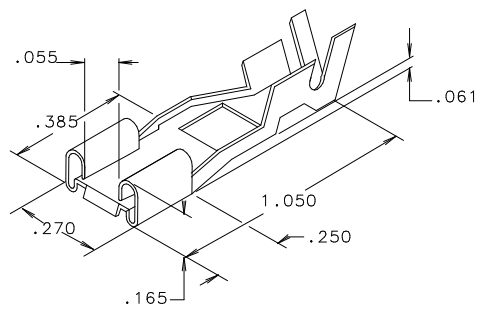

REELED TERMINALS ARE TO UNWIND FROM REEL WITH TERMINALS POSITIONED AS SHOWN

REEL IS APPROX. 19" IN DIA. (NOT DRAWN TO SCALE)

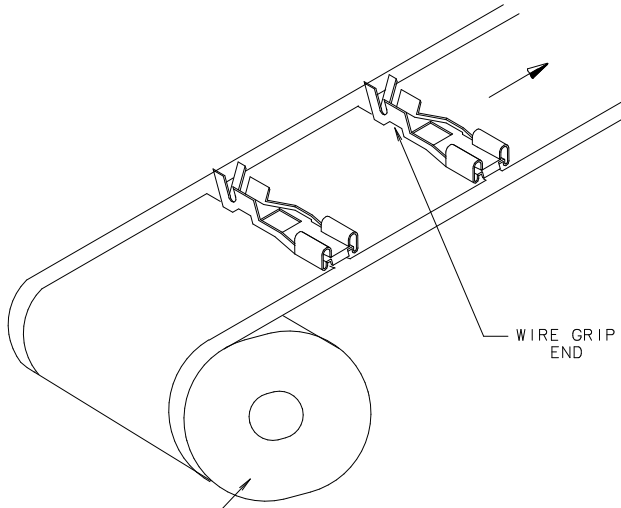

NO	COMPONENT NO	DESCRIPTION	QTY/M	U/M
BILL OF MATERIAL				
MATERIAL SPEC. PRE-HOT TIN DIPPED BRASS CDA 230		FINISH		
COPIES TO	DRW	JMB	DATE	1/13/98
1	9	18	SCALE	---
2	10	19	DATE	SUPER DRW
3	12	20	DATE	RAW STK WT
4	13	21	DATE	
5	14	23	DATE	
6	15	33	DATE	
7	16	43	DATE	
8	17	53	DATE	
TOLERANCE UNLESS OTHERWISE SPECIFIED TWO PLACE DEC ±.01 THREE PLACE DEC ±.005 ANGULAR ±1°				
TITLE				
CRIMP TERMINAL (SALES OUTLINE)				
LTR		REVISION		CHK
C	39059C-	REVISE & REDRAWN ON NEW FORMAT	3/31/98	JMB
D	81212D-	ADDED PT #913-044	5/9/01	JMB

UNLESS OTHERWISE SPECIFIED, DIMENSIONS DO NOT INCLUDE PLATING.	
C	DENOTES CRITICAL CHARACTERISTICS.
C	DENOTES CPK DIMENSIONS - MINIMUM CPK VALUE
C	DENOTES A CHARACTERISTIC THAT PROVIDES AN INDICATION OF PROCESS PERFORMANCE. PROCEDURE FOR MEASUREMENT (STANDARD TRACKING TO BE DEFINED IN LITTELFUSE INSPECTION INSTRUCTIONS.
C	DENOTES CP DIMENSIONS - MINIMUM CP VALUE
C	DENOTES DIMENSIONS THAT ARE CRITICAL TO FUNCTION. DRAWING AND MANUFACTURING LOCATED TO ALLOW FOR MAXIMUM TOOL LIFE.

REVISION	NO.	OUTLINE
D		913-042, -913-044

LITTELFUSE
DES PLAINES, ILLINOIS 60016

