

ELECTRIC DOUBLE LAYER CAPACITORS "EverCAP®"



Screw Terminal Type, High Energy Density Type

- High energy density.
- Suitable for electric power storage.
- Compliant to the RoHS directive (2002/95/EC).



Specifications

Item	Performance Characteristics							
Category Temperature Range	-25 to +60°C							
Rated Voltage Range	2.5V							
Rated Capacitance Range	600 to 4000F See Note							
Capacitance Tolerance	±20% (20°C)							
Leakage Current	0.5C (mA) [C : Rated Capacitance (F)] (After 30 minutes' application of rated voltage. 2.5V)							
Stability at Temperature	Capacitance (-25°C) / Capacitance (+20°C) × 100 ≥ 70% DCR(-25°C) / DCR(+20°C) ≤ 7							
DCR*	Refer to the list below. (20°C) *DC internal resistance							
Endurance	The specifications listed at right shall be met when the capacitors are restored to 20°C after the rated voltage is applied for 2000 hours at 60°C.	<table border="1"> <tr> <td>Capacitance change</td> <td>Within ±30% of the initial capacitance value</td> </tr> <tr> <td>DCR</td> <td>300% or less than the initial value</td> </tr> <tr> <td>Leakage current</td> <td>Less than or equal to the initial specified value</td> </tr> </table>	Capacitance change	Within ±30% of the initial capacitance value	DCR	300% or less than the initial value	Leakage current	Less than or equal to the initial specified value
	Capacitance change	Within ±30% of the initial capacitance value						
	DCR	300% or less than the initial value						
Leakage current	Less than or equal to the initial specified value							
Shelf Life	The specifications listed at right shall be met when the capacitors are restored to 20°C after storing the capacitors under no load for 2000 hours at 60°C.	<table border="1"> <tr> <td>Capacitance change</td> <td>Within ±30% of the initial capacitance value</td> </tr> <tr> <td>DCR</td> <td>300% or less than the initial value</td> </tr> <tr> <td>Leakage current</td> <td>Less than or equal to the initial specified value</td> </tr> </table>	Capacitance change	Within ±30% of the initial capacitance value	DCR	300% or less than the initial value	Leakage current	Less than or equal to the initial specified value
	Capacitance change	Within ±30% of the initial capacitance value						
	DCR	300% or less than the initial value						
Leakage current	Less than or equal to the initial specified value							
Marking	Printed with white color letter on black sleeve.							

Drawing

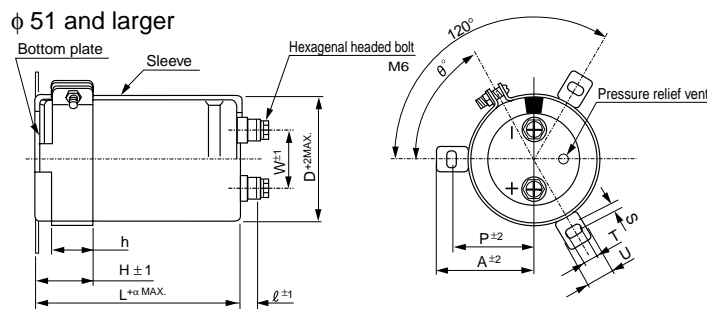
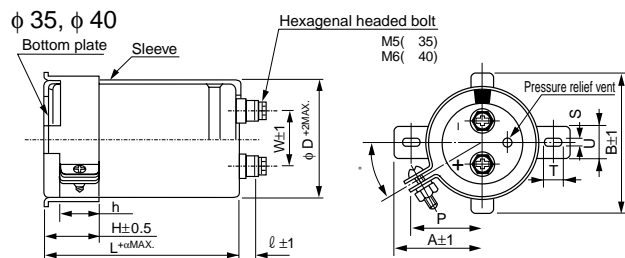

Type numbering system (Example : 2.5V 600F)

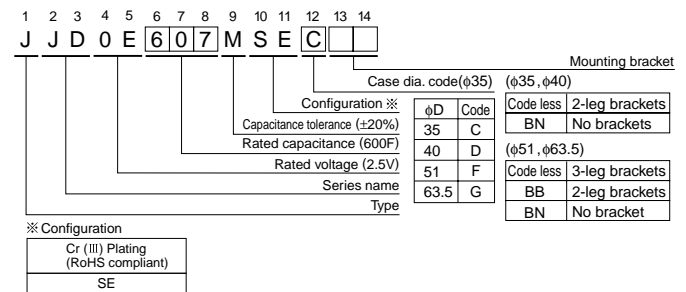

Dimensions

Rated Voltage (Code)	Cap. (F)	Cap. code	DCR ※ Typical (mΩ)	Case size		Ref. Weight (g)
				φ (mm)	L (mm)	
2.5V (0E)	600	607	13.5	35	85	130
	800	807	10.0		105	160
	950	957	8.5		135	210
	1000	108	8.0	40	105	210
	1300	138	6.0		135	250
	2300	238	4.0	51	135	450
	2500	258	3.5		150	500
	4000	408	2.2		63.5	150

※ The listed DCR value is typical and therefore not a guaranteed value.

Dimensions of terminal pitch(W) and length(ℓ) and Normal dia. of bolt (mm)

φ D	W	ℓ	α	Nominal of bolt
35	12.7	6	3	M5
40	18.8	9	3	M6
51	26.0	10	3	M6
63.5	28.6	10	3	M6

Dimensions of mounting bracket (mm)

Symbol	3-Legs			2-Legs		
	51	63.5	35	40	51	63.5
P	32.5	38.1	24	27	33.2	40.5
A	38.5	43	29	32	40	46.5
B	-	-	45	48	-	-
T	7.5	8.0	7.0	7.0	6.0	7.0
S	5.0	5.0	3.5	3.5	4.5	4.5
U	12	14	10	10	14	14
θ°	60	60	30	45	30	30
H	20	25	15	17	25	35
h	15	20	10	12	15	20

Note :

The capacitance calculated from discharge time (ΔT) with constant current (i) after 30minute charge with rated voltage (2.5V). The discharge current (i) is 0.01 × rated capacitance (F). The discharge time (ΔT) measured between 2V and 1V with constant current.

The capacitance calculated below.

$$\text{Capacitance (F)} = i \times \Delta T$$

CAT.8100Z