

Notice for TAIYO YUDEN products

Please read this notice before using the TAIYO YUDEN products.



REMINDERS

- Product information in this catalog is as of October 2008. All of the contents specified herein are subject to change without notice due to technical improvements, etc. Therefore, please check for the latest information carefully before practical application or usage of the Products.

Please note that Taiyo Yuden Co., Ltd. shall not be responsible for any defects in products or equipment incorporating such products, which are caused under the conditions other than those specified in this catalog or individual specification.

- Please contact Taiyo Yuden Co., Ltd. for further details of product specifications as the individual specification is available.
- Please conduct validation and verification of products in actual condition of mounting and operating environment before commercial shipment of the equipment.
- All electronic components or functional modules listed in this catalog are developed, designed and intended for use in general electronics equipment.(for AV, office automation, household, office supply, information service, telecommunications, (such as mobile phone or PC) etc.). Before incorporating the components or devices into any equipment in the field such as transportation,(automotive control, train control, ship control), transportation signal, disaster prevention, medical, public information network (telephone exchange, base station) etc. which may have direct influence to harm or injure a human body, please contact Taiyo Yuden Co., Ltd. for more detail in advance.

Do not incorporate the products into any equipment in fields such as aerospace, aviation, nuclear control, submarine system, military, etc. where higher safety and reliability are especially required.

In addition, even electronic components or functional modules that are used for the general electronic equipment, if the equipment or the electric circuit require high safety or reliability function or performances, a sufficient reliability evaluation check for safety shall be performed before commercial shipment and moreover, due consideration to install a protective circuit is strongly recommended at customer's design stage.

- The contents of this catalog are applicable to the products which are purchased from our sales offices or distributors (so called "TAIYO YUDEN's official sales channel"). It is only applicable to the products purchased from any of TAIYO YUDEN's official sales channel.
- Please note that Taiyo Yuden Co., Ltd. shall have no responsibility for any controversies or disputes that may occur in connection with a third party's intellectual property rights and other related rights arising from your usage of products in this catalog. Taiyo Yuden Co., Ltd. grants no license for such rights.
- Caution for export
Certain items in this catalog may require specific procedures for export according to "Foreign Exchange and Foreign Trade Control Law" of Japan, "U.S. Export Administration Regulations," and other applicable regulations. Should you have any question or inquiry on this matter, please contact our sales staff.
Should you have any question or inquiry on this matter, please contact our sales staff.

コイン型ポリアセンキャパシタ

COIN TYPE PAS CAPACITOR



OPERATING TEMP.	TYPE	Operating temp. range
	HR	-20~+60°C
	TR, SR	-25~+70°C

特長 FEATURES

- 高容量・高信頼性
PASはそのアモルファス構造に多くのイオンを蓄える(ドーピングする)ことができるため、従来の電気二重層コンデンサと比較すると大きな容量を有しています。またPASは極めて安定した素材であり、サイクル寿命、過充電・過放電などの耐久性に優れています。
- RoHS/WEEE指令対応
すべての製品においてRoHS指令の対応を完了しています。リチウムイオン二次電池のような回収・リサイクルの義務はありません。
- 世界最小
外径3.8mm×厚さ1.1mmの世界最小サイズのコイン型キャパシタ[PAS311シリーズ]を開発しました。薄膜電極材料の開発や特殊処理耐熱性ガスケットの採用、封止技術の開発により最小化を実現しました。
- 低電圧化対応
携帯電話やPDAなどの高機能化に伴う内部回路の低電圧化において、2.0V以下の充放電特性に優れた[PAS414TR]を開発しました。薄膜電極材料の改良により、従来比で容量20%アップを実現しました。様々な内部回路電圧に最適な製品を取り揃えています。
- High capacity / High reliability
PAS can store a large number of ions into its amorphous structure (doping), therefore PAS capacitor has much larger capacity than conventional electric double layer capacitor. In addition, PAS is extremely stable material and PAS capacitor shows excellent performance of cycle life and durability to overcharge and overdischarge.
- RoHS / WEEE compliance
PAS capacitors are RoHS and WEEE compliant products and have no recycling and collection duty that is required in lithium ion battery's case.
- The world's smallest capacitor
"PAS311 series" is the world's smallest coin shaped capacitors, which size is diameter 3.8mm × height 1.1mm.
This smallest product was carried out by developing electrode materials, sealing technology and introducing special processed heat resistance gasket.
- Low voltage compliance
Shoei Electronics developed PAS414TR, which has high performance in charging/discharging characteristics with lower than 2.0V setting, in response to low voltage trend for multifunctional mobile phone and PDAs. PAS414TR achieved 20% increase of capacity compared with our conventional line up by improving electrode. We have various types of products suitable for various internal circuit voltages.

用途 APPLICATIONS

- 携帯電話、デジタルカメラ、携帯情報端末(PDA)、携帯ラジオなどのメモリーや時計機能(RTC)バックアップ用電源
- Memory and RTC back-up power source used for cellular phone, PDA, digital camera, portable radio and so on.

形名表記法 ORDERING CODE

1	シリーズ名 PAS ポリアセンキャパシタ	3	厚み寸法 H(mm) 09 0.9 11 1.1 14 1.4	5	共通記号 - 固定
2	外径寸法 φD(mm) 3 3.8 4 4.8	4	最大使用電圧(V) / はんだ付け TR 2.0 鉛フリー リフローはんだ付け SR 2.5(2.6*) 鉛フリー リフローはんだ付け HR 3.3 鉛フリー リフローはんだ付け (*): PAS311SRのみ	6	端子形状 VA5 個別仕様 VA5R 個別仕様 VA6R 個別仕様 VE5 個別仕様 VE5R 個別仕様

P A S 3 1 1 H R - V A 6 R

1	Series name PAS Polyacene Capacitors	3	Height H(mm) 09 0.9 11 1.1 14 1.4	5	Common sign - Fixation
2	Diameter φD(mm) 3 3.8 4 4.8	4	Maximum Usable Voltage(V) / Soldering TR 2.0 Lead Free Reflow Soldering SR 2.5(2.6*) Lead Free Reflow Soldering HR 3.3 Lead Free Reflow Soldering (*): PAS311SR only	6	Lead Terminal VA5 Individually specified VA5R Individually specified VA6R Individually specified VE5 Individually specified VE5R Individually specified

外形寸法 EXTERNAL DIMENSIONS

409-VA5 Type

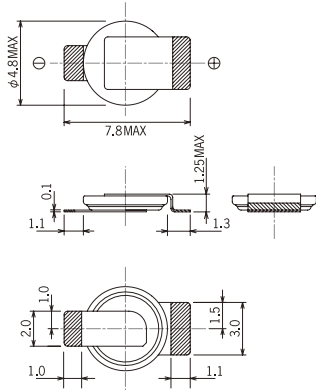

409-VA5R Type

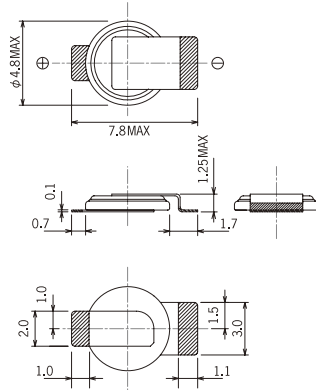

409-VE5 Type

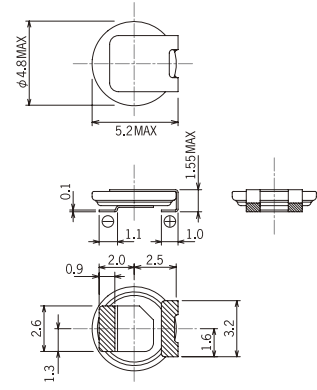

409-VE5R Type

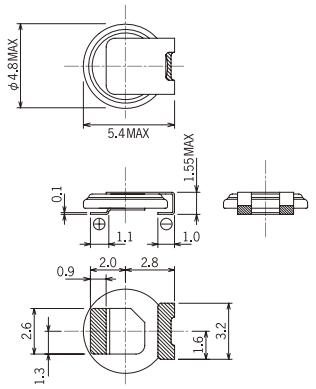

414-VA5 Type

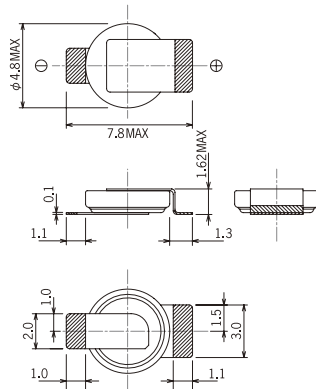

414-VA5R Type

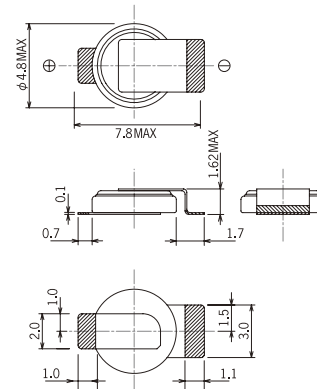

414-VE5 Type

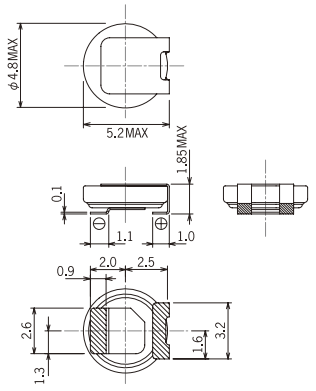

414-VE5R Type

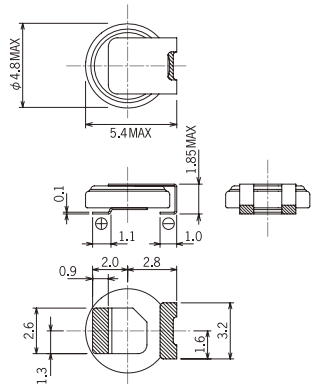

311-VE5R Type

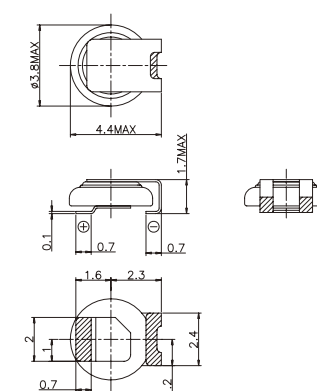

311-VA6R Type

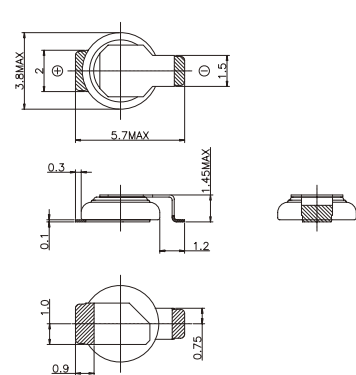

 はんだメッキ部分
 Solder plating area
 (単位: mm)
 (Unit: mm)

セクションガイド
Selection Guide

P.23

etc

アイテム一覧
Part Numbers

P.498

特性図
Electrical Characteristics

P.499

etc

梱包
Packaging

P.503

信頼性
Reliability Data

P.504

使用上の注意
Precautions

P.506

外径寸法、重量 EXTERNAL DIMENSIONS、WEIGHT

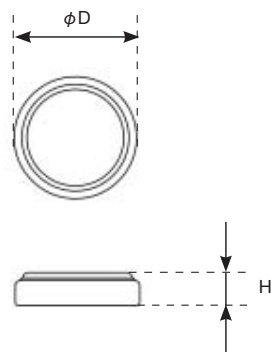

Type	φ D	H	Weight
311	3.8 (0.150)	1.1 (0.043)	0.03
409	4.8 (0.189)	0.9 (0.035)	0.05
414	4.8 (0.189)	1.4 (0.055)	0.06

Unit : mm (inch) unit:g

アイテム一覧 PART NUMBERS

品番 PartNumber	端子形状 TerminalShape	鉛フリーリフロー LeadFree Reflowable	RoHS	最大使用電圧 Maximum Usable Voltage (V)	公称容量 Nominal Capacity (μ Ah)	公称容量 Nominal Capacitance (F)	内部抵抗 typ. Typical Internal Resistance (Ω)																																																																																								
PAS311HR	VA6R	○	○	3.3	10 ¹	0.03	120																																																																																								
	VE5R	○	○					PAS409HR	VA5	○	○	3.3	12 ¹	0.03	100	VA5R	○	○	VE5R	○	○	PAS414HR	VA5	○	○	3.3	20 ¹	0.06	80	VA5R	○	○	VE5	○	○	VE5R	○	○	PAS311SR	VA6R	○	○	2.6	10 ²	0.03	50	VE5R	○	○	PAS409SR	VA5	○	○	2.5	10 ²	0.04	50	VA5R	○	○	VE5	○	○	VE5R	○	○	PAS414SR	VA5	○	○	2.5	18 ²	0.07	50	VA5R	○	○	VE5	○	○	VE5R	○	○	PAS414TR	VA5	○	○	2.0	22 ³	0.08	80	VA5R	○	○	VE5
PAS409HR	VA5	○	○	3.3	12 ¹	0.03	100																																																																																								
	VA5R	○	○																																																																																												
	VE5R	○	○																																																																																												
PAS414HR	VA5	○	○	3.3	20 ¹	0.06	80																																																																																								
	VA5R	○	○																																																																																												
	VE5	○	○																																																																																												
	VE5R	○	○																																																																																												
PAS311SR	VA6R	○	○	2.6	10 ²	0.03	50																																																																																								
	VE5R	○	○																																																																																												
PAS409SR	VA5	○	○	2.5	10 ²	0.04	50																																																																																								
	VA5R	○	○																																																																																												
	VE5	○	○																																																																																												
	VE5R	○	○																																																																																												
PAS414SR	VA5	○	○	2.5	18 ²	0.07	50																																																																																								
	VA5R	○	○																																																																																												
	VE5	○	○																																																																																												
	VE5R	○	○																																																																																												
PAS414TR	VA5	○	○	2.0	22 ³	0.08	80																																																																																								
	VA5R	○	○																																																																																												
	VE5	○	○																																																																																												
	VE5R	○	○																																																																																												

*1 最大使用電圧→2.0V間で測定
 *2 最大使用電圧→1.5V間で測定
 *3 最大使用電圧→1.0Vで測定

*1 Capacity is measured from maximum usable voltage to 2.0V
 *2 Capacity is measured from maximum usable voltage to 1.5V
 *3 Capacity is measured from maximum usable voltage to 1.0V

特長 FEATURES

- ・鉛フリーリフローはんだ付け対応
(リフロー温度は信頼性のページをご参照下さい)
- ・3.3V以下で任意の電圧設定が可能
- ・PAS311HRは世界最小サイズ

- ・Reflowable with lead-free condition.
(Refer to Reliability Data for recommendable reflow pattern).
- ・Voltage can be set free below 3.3V.
- ・PAS311HR is world's smallest size.

仕様 SPECIFICATIONS

品番 Part Number	311HR	409HR	414HR
1. 使用温度範囲 Operating Temp. Range	- 20 ~ + 60°C		
2. 最大使用電圧 Max. Usable Voltage	3.3V		
3. 初期容量規格 (μAh) Initial Capacitance	6 以上 Over 6	7 以上 Over 7	10 以上 Over 10
4. 初期内部抵抗規格 (Ω) Initial Internal Resistance	500 以下 Below 550	300 以下 Below 300	250 以下 Below 250
5. 最大放電電流 (μA) Max. Discharge Current	10	20	20
6. 温度特性 Temperature Characteristics	上限温度 (60°C) 容量: 初期規格値の 90% 以上 下限温度 (- 20°C) 容量: 初期規格値の 50% 以上 Highest temperature (60°C) Capacity: Over 90% of initial spec. Lowest temperature (- 20°C) Capacity: Over 50% of initial spec.		

特性図 ELECTRICAL CHARACTERISTICS

PAS414HR

○充電特性(定抵抗)

Charging characteristics (Constant R)

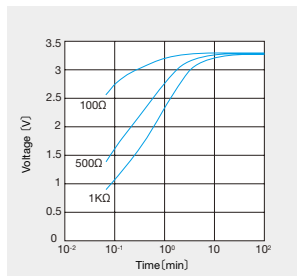

○放電特性(定抵抗)

Discharging characteristics (Constant R)

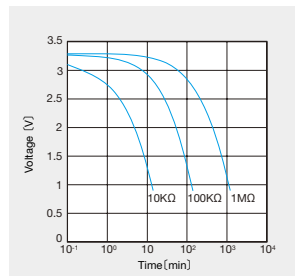

○温度特性

Temperature characteristics

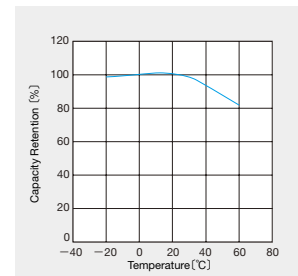

特長 FEATURES

- ・鉛フリーリフローはんだ付け対応
(リフロー温度は信頼性のページをご参照下さい)
- ・2.5V(PAS311SRは2.6V)以下で任意の電圧設定が可能
- ・PAS311SRは世界最小サイズ

- ・Reflowable with lead-free condition.
(Refer to Reliability Data for recommendable reflow pattern).
- ・Voltage can be set free below 2.5V(2.6V for PAS311SR).
- ・PAS311SR is world's smallest size.

仕様 SPECIFICATIONS

品番 Part Number	311SR	409SR	414SR
1. 使用温度範囲 Operating Temp. Range	- 25 ~ + 70°C		
2. 最大使用電圧 Max. Usable Voltage	2.6V	2.5V	2.5V
3. 初期容量規格 (F) Initial Capacitance	0.025 以上 Over 0.025	0.025 以上 Over 0.025	0.05 以上 Over 0.05
4. 初期内部抵抗規格 (Ω) Initial Internal Resistance	120 以下 Below 120	120 以下 Below 120	120 以下 Below 120
5. 最大放電電流 (μA) Max. Discharge Current	10	20	20
6. 温度特性 Temperature Characteristics	上限温度 (70°C) 容量: 初期規格値の 90% 以上 下限温度 (- 25°C) 容量: 初期規格値の 50% 以上 Highest temperature (70°C) Capacitance: Over 90% of initial spec. Lowest temperature (- 25°C) Capacitance: Over 50% of initial spec.		

特性図 ELECTRICAL CHARACTERISTICS

PAS414SR

○充電特性(定抵抗)
Charging characteristics (Constant R)

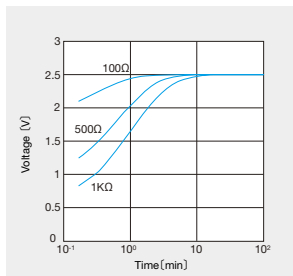

○放電特性(定抵抗)
Discharging characteristics (Constant R)

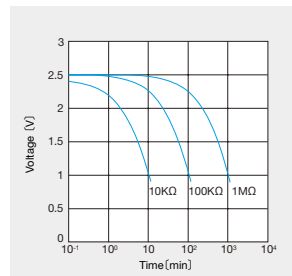

○温度特性
Temperature characteristics

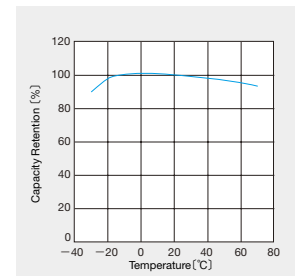

特長 FEATURES

- ・鉛フリーリフローはんだ付け対応
(リフロー温度は信頼性のページをご参照下さい)
- ・2.0V以下で任意の電圧設定が可能
- ・従来比で容量20%アップを実現

- ・Reflowable with lead-free condition.
(Refer to Reliability Data for recommendable reflow pattern).
- ・Voltage can be set free below 2.0V.
- ・PAS311SR is world's smallest size.

仕様 SPECIFICATIONS

品番 Part Number	414TR
1. 使用温度範囲 Operating Temp. Range	-25~+70°C
2. 最大使用電圧 Max. Usable Voltage	2.0V
3. 初期容量規格(F) Initial Capacitance	0.06以上 Over 0.06
4. 初期内部抵抗規格(Ω) Initial Internal Resistance	120以下 Below 120
5. 最大放電電流(μA) Max. Discharge Current	20
6. 温度特性 Temperature Characteristics	上限温度(70°C) 容量: 初期規格値の90%以上 下限温度(-25°C) 容量: 初期規格値の50%以上 Highest temperature(70°C) Capacitance: Over 90% of initial spec. Lowest temperature(-25°C) Capacitance: Over 50% of initial spec.

特性図 ELECTRICAL CHARACTERISTICS

PAS414TR

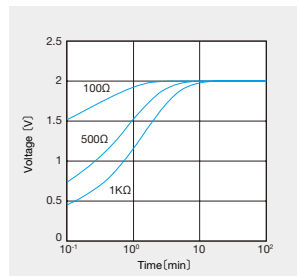
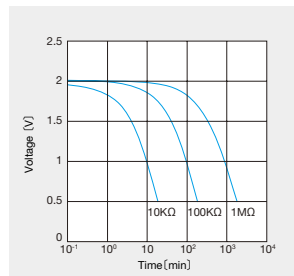
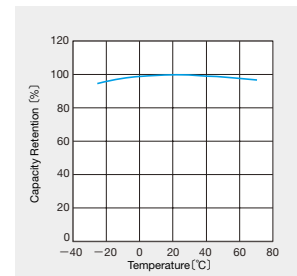
○充電特性(定抵抗)
Charging characteristics (Constant R)○放電特性(定抵抗)
Discharging characteristics (Constant R)○温度特性
Temperature characteristics

○適用1: 携帯電話

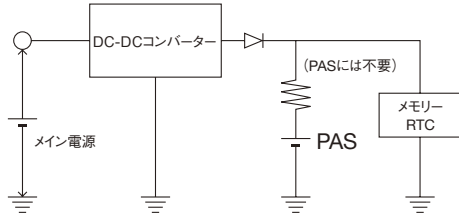

○Application 1: Cellular Phone

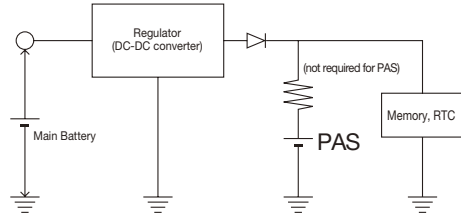

○適用2: 携帯電話

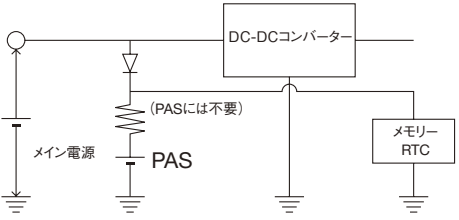

○Application 2: Cellular Phone

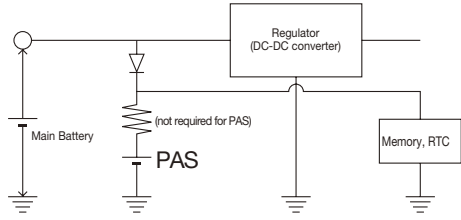

○適用3: 携帯電話

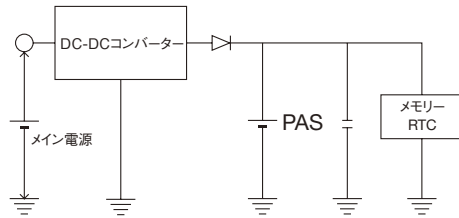

○Application 3: Cellular Phone

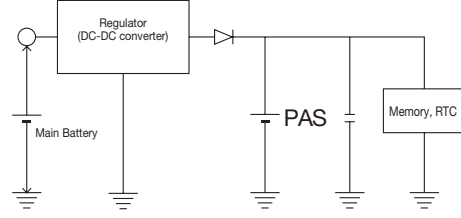

○適用4: メモリーカード

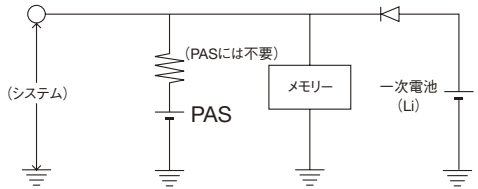

○Application 4: Memory card

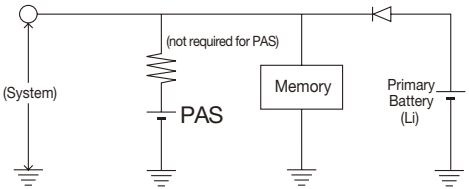

○適用5: ICメモリーカード

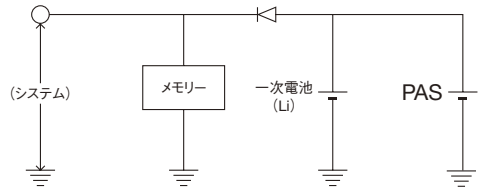

○Application 5: IC Memory card

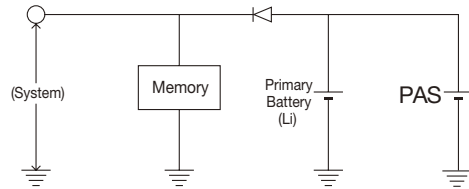

○適用6: ページャー

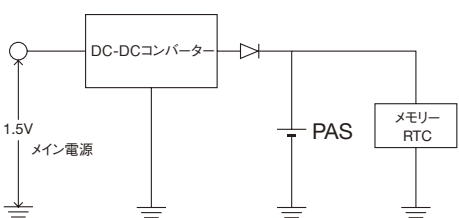

○Application 6: Pager

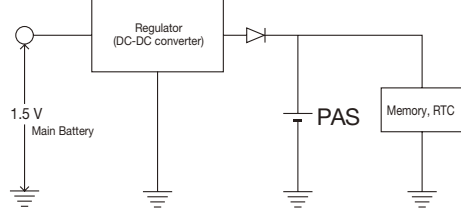

梱包 PACKAGING

① 梱包仕様一覧 Summary Packaging Specifications

アイテム Item	端子形状 Terminal Shape	製品入り数 Quantity per Reel	製品向き ^(*) Products Direction	テープ幅 Tape Width	ピッチ Pitch	リール径 Reel Diameter	エンボス形状 EmbossShape
PAS311 □□	VA6R	4000	—	16.0 ± 0.3	8.0 ± 0.1	330	A
	VE5R	4000	—	16.0 ± 0.3	8.0 ± 0.1	330	B
PAS409 □□	VA5	4000	+	16.0 ± 0.3	8.0 ± 0.1	330	C
	VA5R	4000	—	16.0 ± 0.3	8.0 ± 0.1	330	C
	VE5R	4000	—	16.0 ± 0.3	8.0 ± 0.1	330	C
PAS414 □□	VA5	4000	+	16.0 ± 0.3	8.0 ± 0.1	330	D
	VA5R	4000	—	16.0 ± 0.3	8.0 ± 0.1	330	D
	VE5	4000	+	16.0 ± 0.3	8.0 ± 0.1	330	D
	VE5R	4000	—	16.0 ± 0.3	8.0 ± 0.1	330	D

(*) スプロケット穴に近い方の端子の極性を示す

(*) Indicate the polarity of terminal which is close to sprocket hole.

単位：mm

Unit：mm

② テーピング寸法 Taping Dimensions

単位：mm
Unit：mm

エンボス形状 A Emboss Shape A

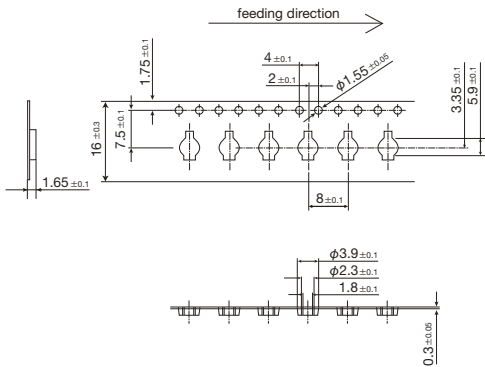

エンボス形状 B Emboss Shape B

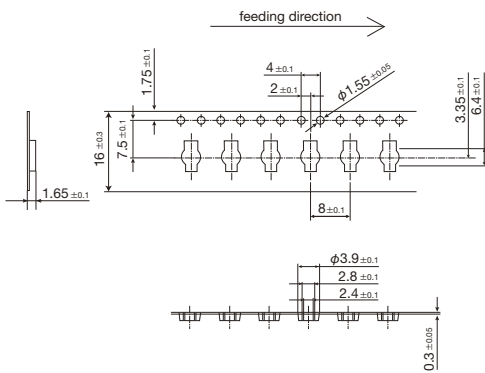

エンボス形状 C Emboss Shape C

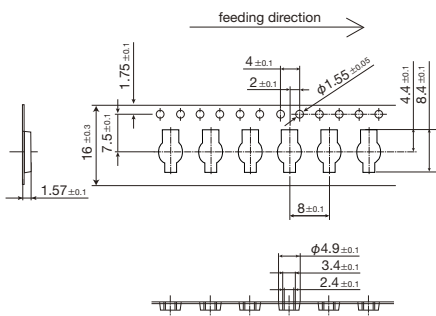

エンボス形状 D Emboss Shape D

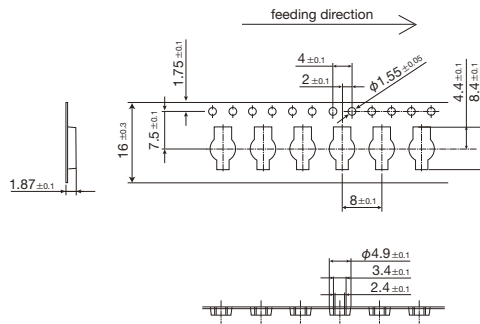

③ リーダー部 トレーラー部 Leader Section/Trailer Section

リーダー部: 400mm以上

(カバーテープにシールされた空ポケットを少なくとも44個ふくむこと)

Leader section : Over 400mm

(Containing at least 44 vacant pockets of carrier tape sealed with top cover tape)

トレーラー部: 40mm以上

(カバーテープにシールされた空ポケット 5個以上)

Trailer section : Over 40mm

(Over 5 vacant pockets of carrier tape sealed with top cover tape)

④ リール寸法 Reel Size

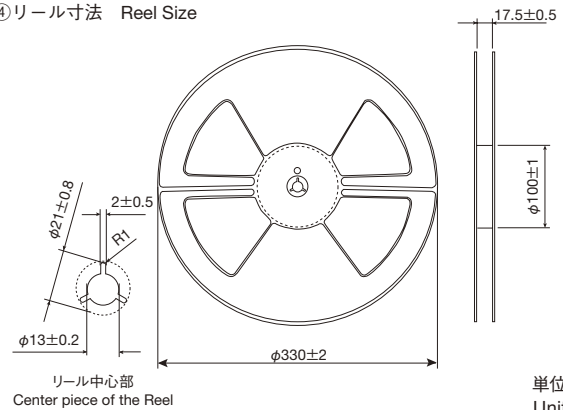

単位：mm
Unit：mm

⑤ 剥離強度 Peel Strength

下図の条件にて、0.1~0.7N

0.1~0.7N under the condition of below figure.

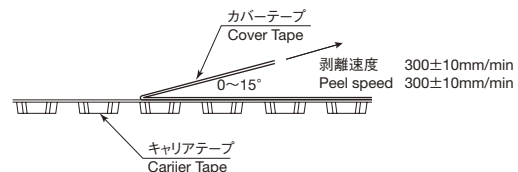

RELIABILITY DATA

Items	Specifications			Test Conditions, Remark
	HR type	SR type	TR type	
1. Operating Temperature range	- 20 ~ + 60°C	- 25 ~ + 70°C	- 25 ~ + 70°C	
2. Max. Usable Voltage	3.3V	2.5V (2.6*)	2.0V	
3. Resistance to Reflow Soldering Heat	Capacity : Within initial spec. Appearance : No noticeable abnormality			Conduct reflow soldering twice according to under mentioned reflow soldering test condition ,and return to normal temperature and humidity.(Conduct the reflow in the condition of the voltage of 0.3V or lower.)
4. Floating Charge Characteristics	Capacity : Over 70% of initial spec. Appearance : No noticeable abnormality			Apply a max. usable voltage to capacitor for 500 hours at max. operating temp. and measure the floating charge characteristics after returning to normal temperature and humidity.
5. Charge/Discharge Cycle Characteristics	Capacity : Over 50% of initial spec. Appearance : No noticeable abnormality			Measure the charge/discharge cycle characteristics after 10000 charge/discharge cycle at 25 ± 5 °C with under mentioned charge/discharge cycle test condition for each parts.
6. Thermal Durability	Capacity : Over 80% of initial spec. Appearance : No noticeable abnormality			Leave the capacitor in an atmosphere of 85°C ± 2°C and - 30 ± 2°C consecutively for 96 hours each, and return to normal temperature and humidity.
7. Humidity Durability	Capacity : Over 80% of initial spec. Appearance : No noticeable abnormality			Temperature : 40 ± 2 °C、Humidity:90 ~ 95%RH Leave the capacitor for 96 hours, and return to normal temperature and humidity.
8. Vibration Durability	No exterior abnormality observed: initial spec. values retained			Apply a sine wave vibration of 1.5mm amplitude and frequency 10 ~ 55Hz, for 2 hours per each direction(X,Y and Z), total 6 hours.

(*) 2.6V for PAS311SR

Reflow Soldering Test Condition

○Reflow profile with lead free condition (HR/SR/TR)

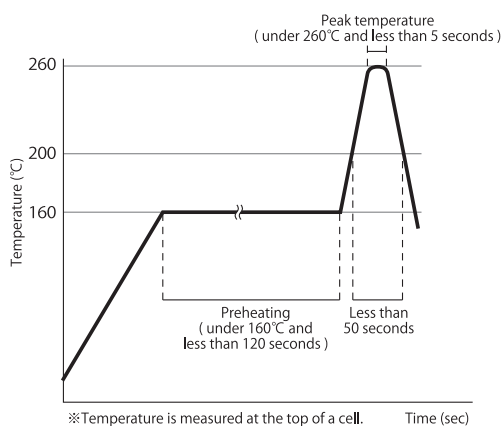

Cautions : Do not charge prior to reflow.
Set reflow condition with in the range provided in "Specifications", which will be published separately.
Consult with us about the details.

Charge/Discharge Cycle Test Condition

Parts umber	311HR	409HR	414HR	311SR	409SR	414SR	414TR
Charging/Discharging Resistance (Ω)	3000	3000	3000	150	150	150	150
Charging Voltage (V)	3.3	3.3	3.3	2.5	2.5	2.5	2.0
Charging Time (min)	12	12	24	5	9	9	5
Discharging Time (min)	3	3	6	1	1	1	1

PRECAUTIONS

1.	Use under the maximum usable voltage. If over maximum usable voltage is applied, it might cause abnormal current flow, which shorten lifetime and sometimes damage PAS capacitor.
2.	Use under surrounding temperature kept as normal as possible. Lifetime of PAS capacitor is greatly affected by surrounding temperature. Each 10°C drop in temperature extends its expected lifetime approximately twice as much. Therefore, avoid high temperature and use PAS capacitor under lower temperature than the maximum operating temperature range.
3.	Mind voltage drop when back-up. When discharging (back-up) start, voltage drop occurs by actuating current and internal resistance in the cell. Consult us beforehand in case if discharging current of 311 type is over 10 μ A and over 20 μ A for 409/414 type .
4.	Consult us when using PAS capacitors in a series connection. In case of using PAS capacitors in series connection, the voltage of each capacitor is not always equal and it may be occurred excessive voltage in a part of capacitor, which may lead to shortening lifetime and breakdown.
5.	Pay sufficient attention to use PAS in circuit with high ripple current. Since PAS capacitor has higher internal resistance than electric capacitor, ripple current may heat up capacitor body, which might cause the increase of internal resistance and deterioration of capacity.
6.	Do not expose PAS capacitor into high humidity, alkaline or acid air. In case PAS capacitor is used in high humidity, alkaline or acid air, lead terminal and container may be damaged. Also, it may cause deteriorating of its performance.
7.	Do not touch with printed pattern. If product touch with printed pattern, short-circuit occurs. Additionally, in case of there is a printed pattern under the product, it may occur short-circuit caused by a breakage of resist.
8.	Mind the polarity of PAS capacitor when soldering on board. Identify the indication of polarity or terminal shapes when installing. If counter current is applied, it might deteriorate capacity and increase internal resistance. It may turn out to be a breakage of product.
9.	Caution on soldering <ul style="list-style-type: none"> • Follow the scope of conditions regulated in specifications. • Do not charge prior to reflowing. • Consult us for details about reflow condition.
10.	Consult us about cleaning condition when cleaning circuit-board after soldering. Cleaning may affect PAS capacitor. Consult us about cleaning conditions beforehand.
11.	Avoid excessive vibration. Excessive vibration may be a cause of breaking soldering part and damaging terminal.
12.	Storage Keep following cautions for storage: <ul style="list-style-type: none"> • Use Shoei Electronics' s tray or reel. For moving on to another tray, do not bend terminals. • Store under normal atmosphere. Sudden change of temperature or high humid condition deteriorates the performance. • Avoid dust and direct sunlight.
13.	Other cautions <ul style="list-style-type: none"> • Do not heat or throw into fire. • Do not short-circuit. • Do not direct soldering to cell body. • Do not dismantle. • Do not deform. • Mind the edge of terminals.