

Type 944U Polypropylene, DC Filter Capacitors

High Current, Low Profile for Inverter Applications



Type 944U is specifically designed for use in high power DC filtering applications. The low inductance internal construction utilizes low loss metallized polypropylene for high ripple current capability. Male or female terminal options offer design flexibility in a rugged UL 94V0 rated flame retardant plastic case and resin fill. High current ratings and robust mounting flanges make the 944U suited for inverter applications in electric vehicle power inverters, wind power inverters and motor drives.

Highlights

- Low Inductance
- Low Profile
- Low ESR
- High Ripple Current
- High Voltage Ratings

Specifications

Capacitance Range	33 μ F to 220 μ F
Capacitance Tolerance	\pm 10% standard
Rated Voltage	800 Vdc to 1400 Vdc
Operating Temperature Range with Ripple	-40 $^{\circ}$ C to 85 $^{\circ}$ C
Maximum rms Current	74A @ 55 $^{\circ}$ C
Maximum rms Voltage	<230 Vac
Test Voltage between Terminal @ 25 $^{\circ}$ C	150% rated Vdc 10 s
Test Voltage between Terminals & Case @ 25 $^{\circ}$ C	4000 Vac 60 s
Life Test	5000 h @ 85 $^{\circ}$ C, rated voltage

Dimensions

Dimensions: Millimeters
H dimension in Ratings Table

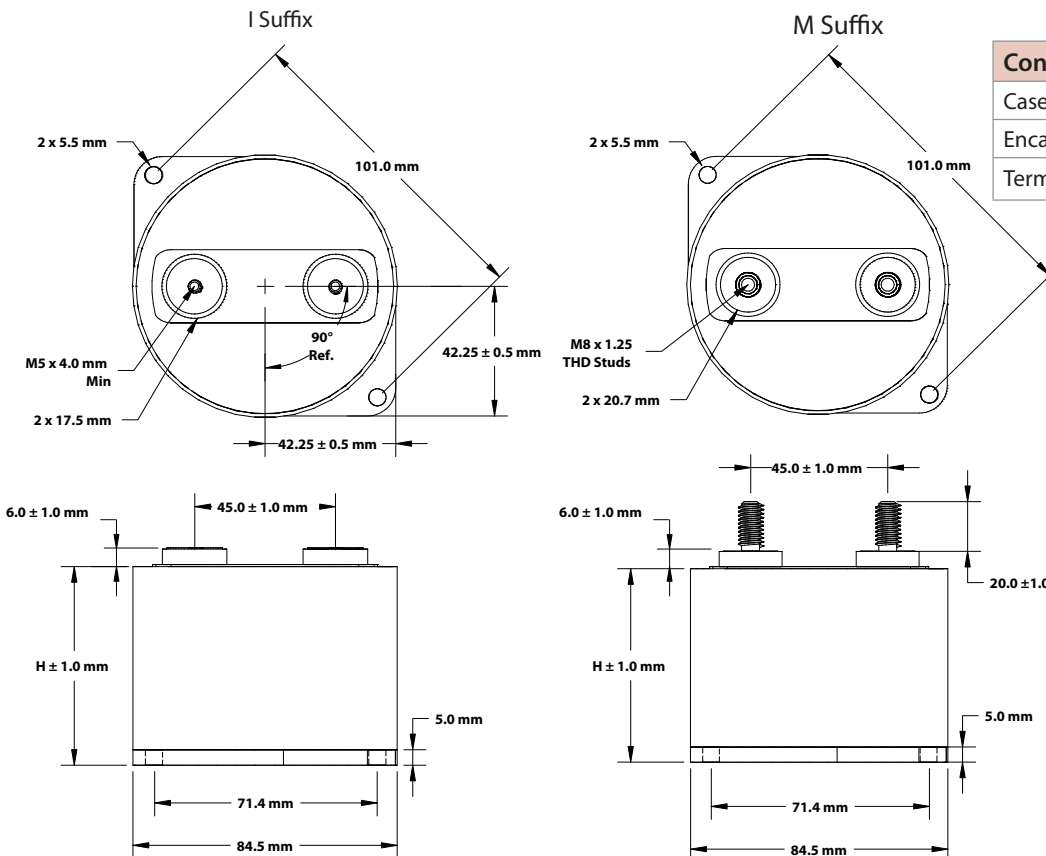

Construction Details	
Case Material	Plastic UL94V-0
Encapsulation	UL94V-0 Resin
Terminal Material	Tin Plated Brass



Type 944U Polypropylene Film Capacitor for DC Filtering

Metallized Polypropylene Dielectric Part Numbering System

944U	101	K	801	A	A	M
Type	Capacitance	Tolerance	Voltage	Diameter D (mm)	Height H (mm)	Terminal
944U	101 = 100 μ F 700 = 70 μ F 470 = 47 μ F	K = \pm 10%	801 = 800 Vdc 102 = 1000 Vdc 122 = 1200 Vdc 142 = 1400 Vdc	A = 84.5	A = 40 B = 51 C = 64	M = M8 Thd Stud I = M5 Thd Insert

Ratings

Catalog Part Number	Cap (μ F)	Rated Voltage (Vdc)	H Height mm	Max ESR 10kHz (m Ω)	Typical ESL (nH)	Max Irms 55°C (A)	Thermal Resistance Θ_{cc} ($^{\circ}$ C/W)	Θ_{ca} ($^{\circ}$ C/W)
944U101K801AA*	100	800	40	0.5	20	74	2.8	5.2
944U161K801AB*	160	800	51	0.8	30	73	3.0	4.5
944U221K801AC*	220	800	64	1.0	40	72	3.1	4.0
944U660K102AA*	66	1000	40	0.6	20	70	2.8	5.2
944U101K102AB*	100	1000	51	0.8	30	68	3.0	4.5
944U141K102AC*	140	1000	64	1.0	40	65	3.1	4.0
944U470K122AA*	47	1200	40	0.7	20	67	2.8	5.2
944U700K122AB*	70	1200	51	1.0	30	65	3.0	4.5
944U101K122AC*	100	1200	64	1.3	40	64	3.1	4.0
944U330K142AA*	33	1400	40	0.8	20	64	2.8	5.2
944U520K142AB*	52	1400	51	1.1	30	60	3.0	4.5
944U700K142AC*	70	1400	64	1.4	40	59	3.1	4.0

* M = M8 Stud I = M5 Insert

Additional values available upon request.

Typical Performance Curves

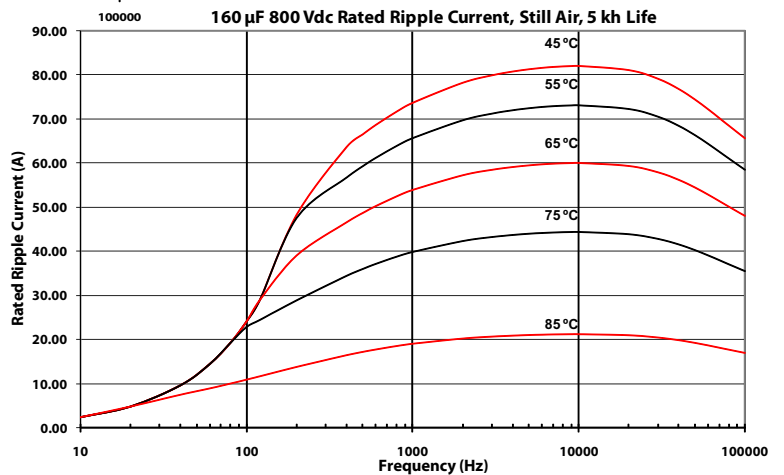
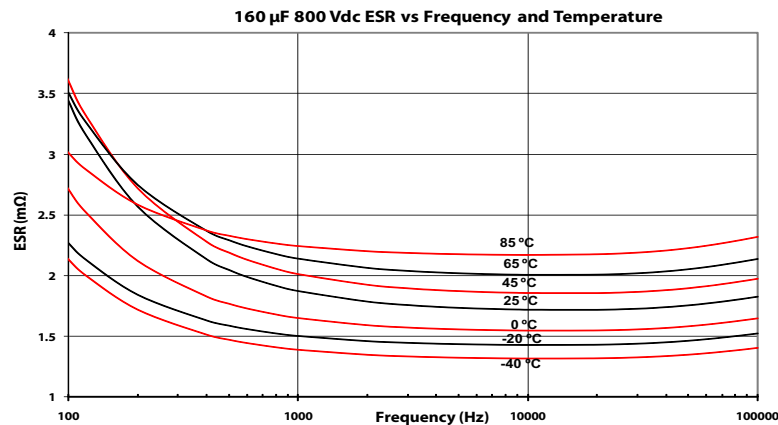



Type 944U Polypropylene Film Capacitor for DC Filtering

Metallized Polypropylene Dielectric Expected Lifetime Predictions

To use the Expected Lifetime curves calculate V_a/V_r and core temperature T . Start by estimating:

- Applied dc voltage V_a
- Ripple Current I
- Ripple Frequency f
- Ambient Temperature T_a
- Airflow speed v

Units:

- $A = m^2$
- $C = \mu F$
- $ESR = m\Omega$
- $f = kHz$
- $I = A$
- $T, T_a \& T_c = ^\circ C$
- $\theta, \theta_{ca} \& \theta_{cc} = ^\circ C/W$
- $v = m/s$
- $V_a \& V_r = V_{dc}$

NOTE: The temperature rise in the 944U is $I^2(ESR)$ times the thermal resistance θ . The ESR is mainly the metal resistance; the metal resistance is the 10 kHz ESR. For operation below 10kHz add the dielectric resistance. It is the dielectric dissipation factor—no more than 0.0002—times the capacitive reactance, i.e., $0.0002 / (2\pi f C)$. That's equal to $31.83 / (fC)$.

1. Start with the 10 kHz ESR from the Ratings table. If frequency is less than 10 kHz, add $31.83 / (fC)$.

2. Compute total thermal resistance θ as the sum of core-to-case thermal resistance θ_{cc} and case-to-ambient thermal resistance θ_{ca} . Both are in the Ratings table but θ_{ca} is for still air and θ_{cc} is for 10 kHz or less. For frequency > 10 kHz multiply θ_{cc} by $[1 + (f - 10) / 100]$, e.g., for 75 kHz multiply θ_{cc} by 1.65. For moving air use the capacitor surface area A and airflow speed v to calculate $\theta_{ca} = 1 / [A(5 + 17.5(v + 0.1)^{0.66})]$.

3. Compute V_a/V_r and the core temperature T .
 $T = T_a + I^2(ESR)\theta$

4. Look up estimated lifetime from the Expected Lifetime curves.

5. If you want a longer expected lifetime, choose a capacitor with higher voltage rating or consider using multiple capacitors in parallel to share the ripple current.

The expected lifetime predictions assume no exposure to overvoltage transients. Expected lifetime can be calculated for varying exposure to overvoltage transients. As an illustration at 50 °C the expected lifetime is 100,000 h with the 24-hour V_a/V_r .

V_a / V_r	Duration
1.67	100 ms
1.50	5 m
1.30	2.5 h
1.10	9.6 h
1.00	11.9 h

For applications with more severe 24-hour profiles, contact us.

