

Specifications:

connector description (1)	dc plug, 6.5x3.0x24 mm, molding style, P/N 50-00090
overmold (2)	30P, PVC, black
wire description (3)	2C, 18 AWG, UL2468, 300V, 80C, 4.4 mm, VW-1, PVC, 48P, P/N 30-00007
cable outer diameter	Ø4.4 mm
cable color	black
cable length	1830 ± 50 mm
twist tie (4)	black

Notes:

Function test: no open, no reversed polarity, no short circuit, no INT
 RoHS compliant
 Hi-Pot test: 600 Vac, 0.5 mA, 1 second

Mechanical drawing:

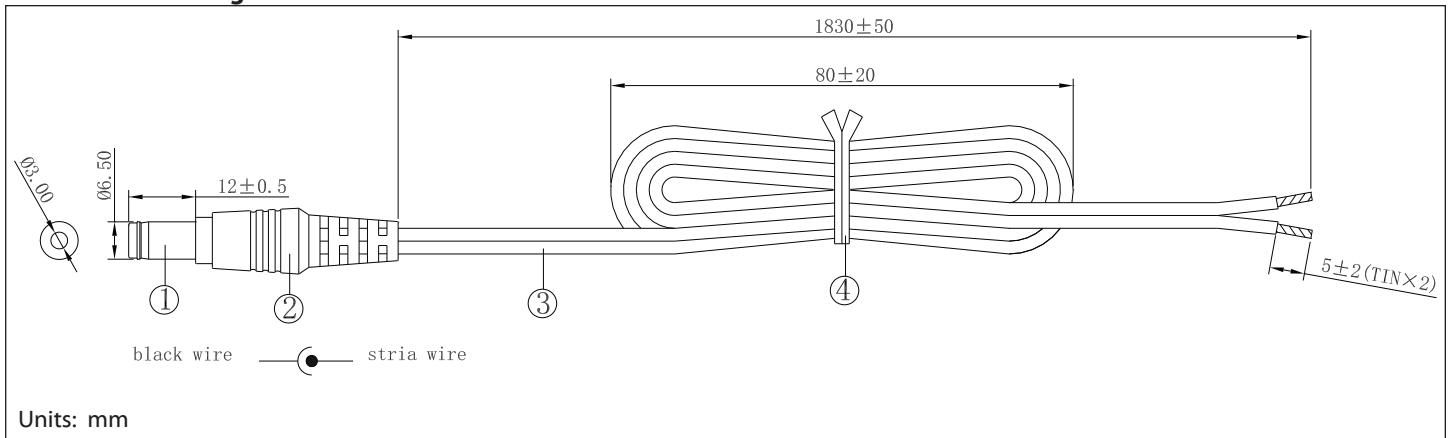

tolerance X: ±0.5 mm .X: ±0.3 mm .XX: ±0.05 mm
 applicable unless otherwise indicated in specification or on drawings
 Tensility International Corporation reserves the right to substitute
 parts which are functionally equivalent to the ones specified.

Initial	Date
---------	------

Revision notes:

Rev	Date	Description
A	March 29, 2010	Re-issued; original specification issued by CUI, re-issued by Tensility without any material or mechanical changes.
A1	August 31, 2011	updated description, connector, and wire information

Specification Approval

Spec sign-off verifies that you have reviewed the entire specification, tested a sample of the product, and confirm that it meets your requirements. This specification reflects the part as it will be ordered. Orders will not be processed until the specification pages have been initialed and the approval page has been signed. This specification is confidential and is not to be transmitted without prior approval from Tensility.

Signature _____ Title _____
 Name _____ Date _____
 Company _____ Branch _____