

Type 4 Mild Steel Two Door Floormount Enclosure 1422 N4 FM

Series

Continuous Hinge Door with Clamps



Application

- Designed to house electrical, electronic, hydraulic or pneumatic controls and instruments.
- Provides protection where equipment may be hosed down or otherwise be very wet, or in outdoor applications for full weather protection.

Standards

- UL 508 Type 3R, 4 and 12
- CSA Type 3R, 4 and 12
- Complies with
 - NEMA Type 3R, 4 12 and 13
 - JIC EGP-1-1967
 - IEC 60529, IP66

Construction

- Formed 12 gauge steel.
- Smooth, continuously welded seams without knockouts, cutouts or holes.
- Body stiffeners are provided in the larger enclosures for extra rigidity.
- Heavy duty lifting eyebolts are provided with reinforcing support angles.
- Center post is removable for easy installation of the inner panel.
- Formed lip on door and top of enclosure opening exclude flowing liquids and contaminants.
- Continuously hinged doors may be removed by pulling the stainless steel hinge pin.
- Doors are secured with heavy duty stainless steel clamps.
- Provision for padlocking.
- 12" floor stands are welded to the enclosure.
- Seamless poured-in place gasket.
- Provision for light kit mounting.
- A removable 10 gauge inner panel is included.
- Panel supports are provided for easy panel installation.
- Collar studs are provided for mounting inner panels.
- A bonding stud is provided on the door and a grounding stud is provided in the enclosure for each door.
- A literature pocket is provided for the inside of the door.

Finish

- Cover and enclosure are finished in recoatable smooth ANSI 61 gray powder coating.
- Removable white inner panel is finished in white powder coating.

Accessories

[Inner Panels](#)

[Blowers and Fans](#)

[Door Stop Kit](#)

[Enclosure Stabilizers](#)

[Floor Stand Kit](#)

[Gland Plates](#)

[Type 1 Louvered Ventilating Plates](#)

[Window Kits](#)

[Cooling Products](#)

[Ventilation](#)

[Drip Shield Kit](#)

[Filtered Fans](#)

[Heaters](#)

[Lighting](#)

[Temperature Controls](#)

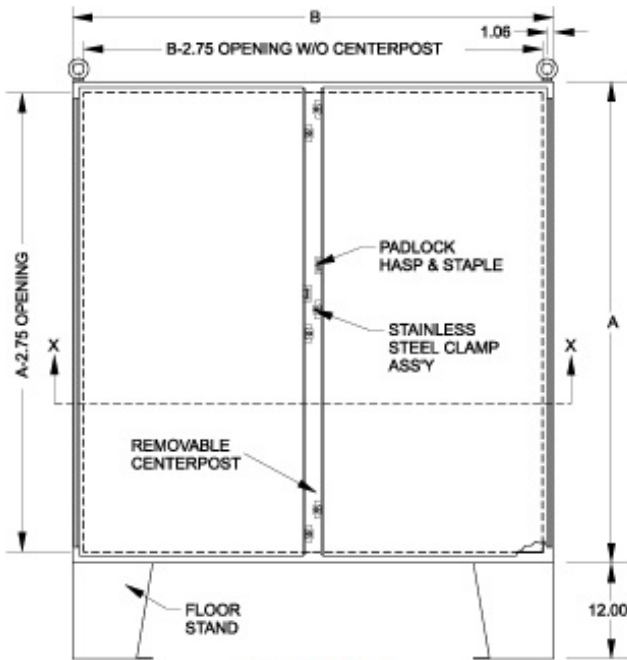

Front View

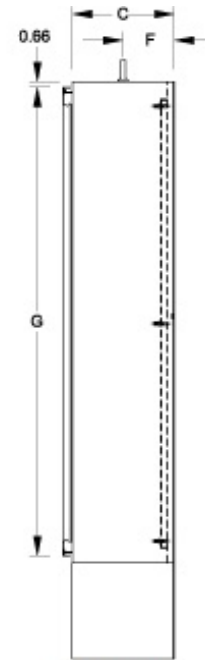

Side View

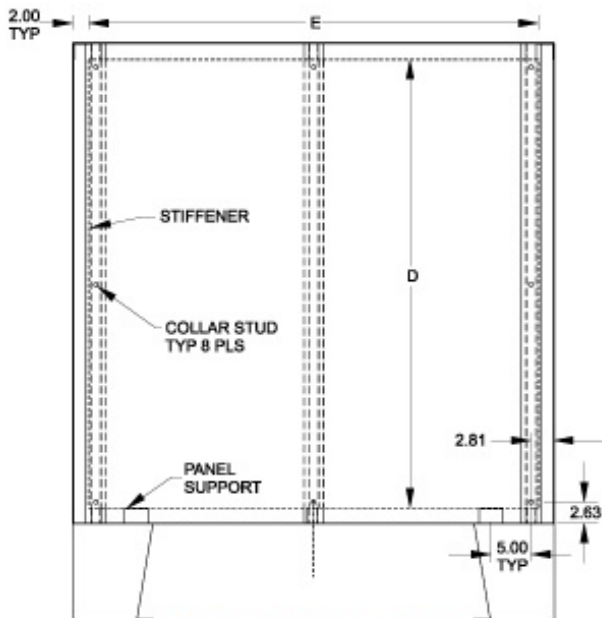

View with Doors Open

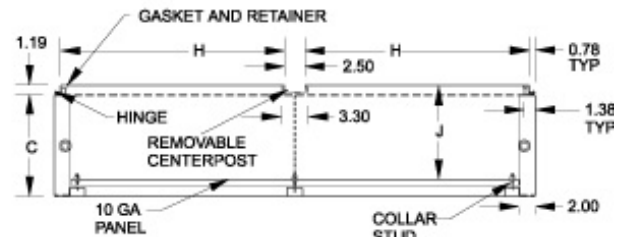

Section X-X

w/ Feet												Ship Wt.
Part No.	A	B	C	Body Gauge	Panel Gauge	Panel Size		F	G	H	J	(lbs)
1422N4B10F	60.13	48.06	10.69	12	10	D	E	5.30	58.59	22.00	9.87	475

1422N4D12F	60.13	60.06	12.69	12	10	56.00	56.00	6.30	58.59	28.00	11.87	567
1422N4E12F	72.13	60.06	12.69	12	10	68.00	56.00	6.30	70.59	28.00	11.87	645
1422N4F12F	72.13	72.06	12.69	12	10	68.00	68.00	6.30	70.59	34.00	11.87	750
1422N4F24F	72.13	72.06	24.69	12	10	68.00	68.00	12.30	70.59	34.00	23.87	945

Data subject to change without notice.

© 2013. Hammond Manufacturing Ltd. All rights reserved.